

Anti vibration  
mounts

# ST + SYLOMER®

**ASCALEX**  
3755 Place Java, Local 160  
Brossard, Qc.  
J4Y 0E4

Contrôle  
Bruits  
Vibrations  
Vibrations  
Noises  
Control

**AMC**  
MECANOCAUCHO  
NOISE AND  
VIBRATION  
SOLUTIONS



The AMC-MECANOCAUCHO® type ST+Sylomer® is ideal for high performance building acoustics as well as for stationary applications where the acoustic hanger must provide a high degree of structure borne noise isolation. Thanks to their low stiffness they are capable of achieving natural frequencies ranging from 3 to 4Hz. Due to this fact they are often used on applications where a high isolation degree is required even at low disturbing frequencies (600 to 1000 rpm).

## TECHNICAL CHARACTERISTICS

The design of these acoustic hangers is composed of:

- 1. Metal parts that are mechanically failsafe.
- 2. A rubber moulded part equipped with an end stroke buffer if ever the acoustic hanger is overloaded.
- 3. A prime degree steel coil spring to provide low natural frequency to the acoustic hanger.
- 4. A Sylomer® layer to isolate mid-high frequencies that could travel through the coil spring.

These mounts are equipped with different types of coil springs to suit different loading applications from 5 to 60 Kg per hanger.



DRAWINGS

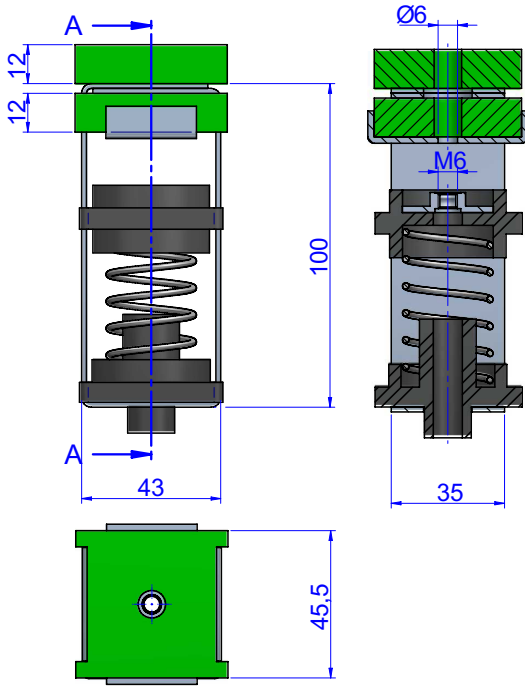

DIMENSIONS

Type	Max. Permanent Load (kg)	Spring color	M	Weight (kg)	Code
ST + Sylomer ST-5	5	Silver	M6	0,198	23425
			M8	0,198	23336
ST + Sylomer ST-10	10	White	M6	0,198	23398
			M8	0,198	23446
ST + Sylomer ST-20	20	Yellow	M6	0,198	23420
			M8	0,198	23447
ST + Sylomer ST-30	30	Blue	M6	0,198	23400
			M8	0,198	23338
ST + Sylomer ST-60	60	Magenta	M6	0,198	23397
			M8	0,198	23340

Elastical properties

### LOAD DEFLECTION N GRAPH ST + SYLOMER®

