

Anti vibration  
mounts

# FZH + SYLOMER® FLOATING FLOOR MOUNTS

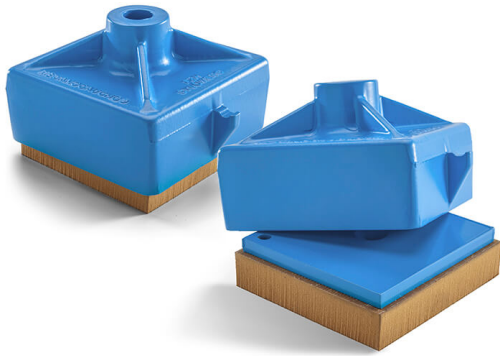

The goal of the system is to avoid the structure borne noise installing elastical mounts that are embedded in the concrete floating floor .The process of elevation is done once the concrete is dry. The AMC-MECANOCAUCHO type FZH mounts incorporate a polyurethane elastomer called Sylomer®. This material offers optimal elastic and mechanical properties for the application. The AMC-MECANOCAUCHO type FZH mounts can be manufactured in different densities of Sylomer® to match the natural frequency needed on the application. The process of leveling is simple and effective. The density of mount per m2 is 1.12 and the distance between the mounts is 0,9m.

## TECHNICAL CHARACTERISTICS

The AMC-MECANOCAUCHO type FZH mounts incorporate a polyurethane elastomer called Sylomer®. This material offers optimal elastic and mechanical properties for the application.

The AMC-MECANOCAUCHO type FZH mounts can be manufactured in different densities of Sylomer to match the natural frequency needed on the application.

The process of leveling is simple and effective. The density of mount per m2 is 1.12 and the distance between the mounts is 0,9m.

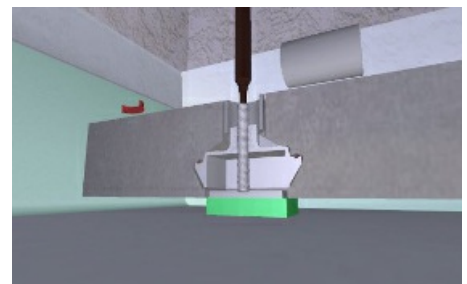
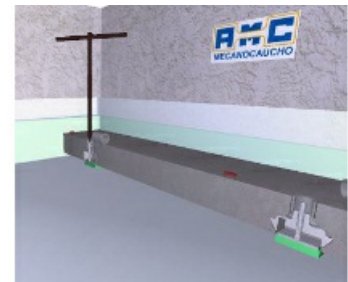
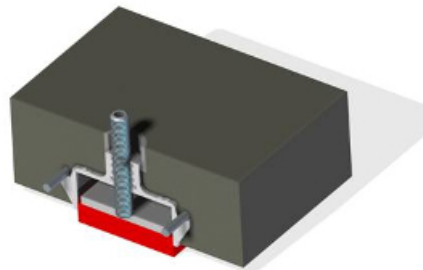

## ADVANTAGES



- **LOW-LEVEL**, optimum efficiency damped screeds without much height is achieved. Given that the available height is severely limited in many cases, the entire available height becomes concrete slab system and adding mass to lower the natural frequency getting
- High insulation, anti-vibration characteristics thanks to the Sylomer and used in tacos, very low natural frequencies that provide optimum insulation are achieved.
- Quick installation without placing board or joints between boards.
- Economy, save assembly time, we need boards or tacos.
- Safety, avoid the appearance of acoustic bridges, as when lifting the slab we are 100% sure that there has been no error in making the slab.
- Easy and simple assembly, it does not take a specialist to perform this ground.

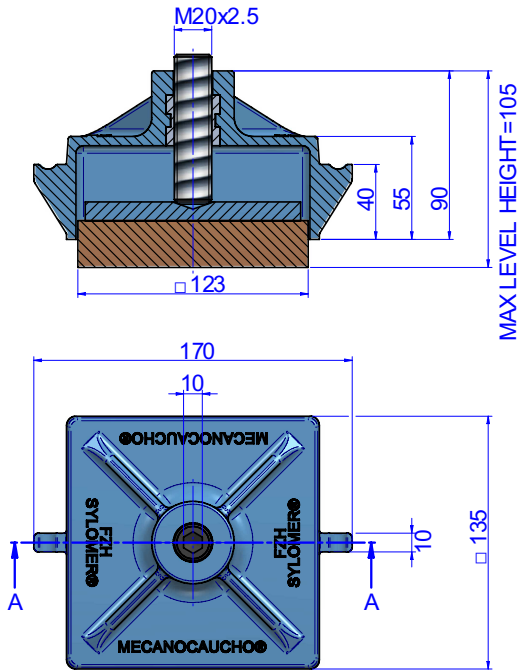

DIMENSIONS

	Type	SUMMARY	LOAD kg MAX	FREQ. Hz. MAX Load	Weight (kg)	Code
	FZH-33-25	Concrete embedded Jack up mounts, designed for the antivibration suspension of slabs.	140	11	1,12	176511
	FZH-39-25	Concrete embedded Jack up mounts, designed for the antivibration suspension of slabs.	240	11,1	1,24	176513
	FZH-45-25	Concrete embedded Jack up mounts, designed for the antivibration suspension of slabs.	490	10,4	2,4	176515
	FZH-51-25	Concrete embedded Jack up mounts, designed for the antivibration suspension of slabs.	800	11,8	1,53	176517

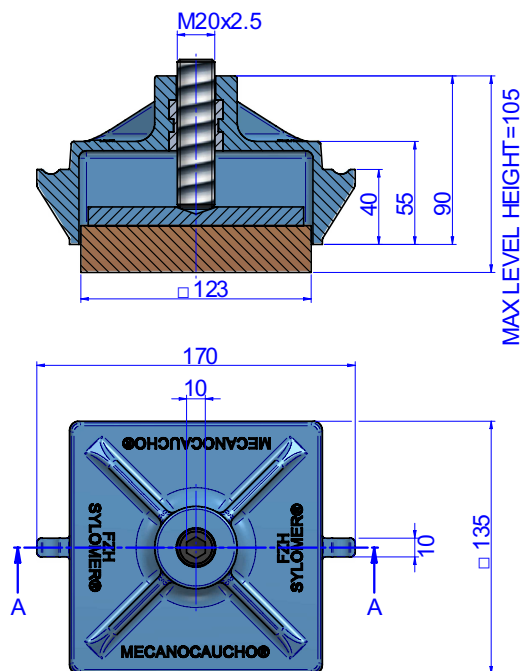

## DIMENSIONS

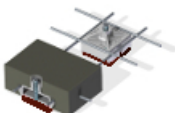
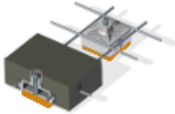
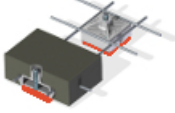
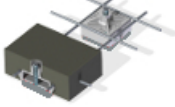
	Type	SUMMARY	LOAD kg MAX	FREQ. Hz. MAX Load	Weight (kg)	Code
	FZH-57-25	Concrete embedded Jack up mounts, designed for the antivibration suspension of slabs.	960	11,7	1,61	176519
	FZH-33-37	Concrete embedded Jack up mounts, designed for the antivibration suspension of slabs	140	8,6	1,64	176512
	FZH-39-37	Concrete embedded Jack up mounts, designed for the antivibration suspension of slabs.	240	8,5	1,82	176514
	FZH-45-37	Concrete embedded Jack up mounts, designed for the antivibration suspension of slabs.	490	8,1	1,94	176516

Anti vibration  
mounts

## FZH + SYLOMER® FLOATING FLOOR MOUNTS

### DRAWINGS

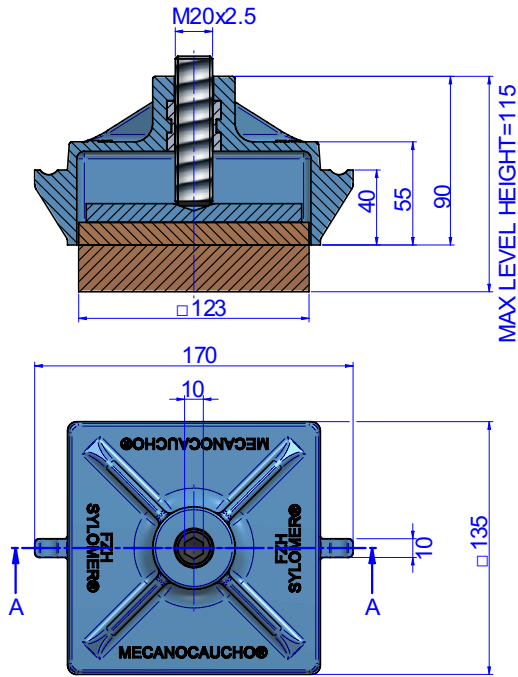

**ASCALEX**  
3755 Place Java, Local 160  
Brossard, Qc.  
J4Y 0E4

Contrôle  
Bruits  
Vibrations  
Noises  
Control

**BMC**  
MECANOCAUCHO  
NOISE AND  
VIBRATION  
SOLUTIONS

### DIMENSIONS

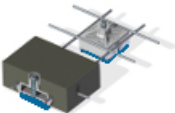
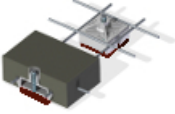
	Type	SUMMARY	LOAD kg MAX	FREQ. Hz. MAX Load	Weight (kg)	Code
	FZH-51-37	Concrete embedded Jack up mounts, designed for the antivibration suspension of slabs.	800	9,1	2,11	176518
	FZH-57-37	Concrete embedded Jack up mounts, designed for the antivibration suspension of slabs.	960	8,4	2,29	176520

# FZH + SYLOMER® FLOATING FLOOR MOUNTS

Elastical properties

NATURAL FREQUENCY  
FZH + SYLOMER®

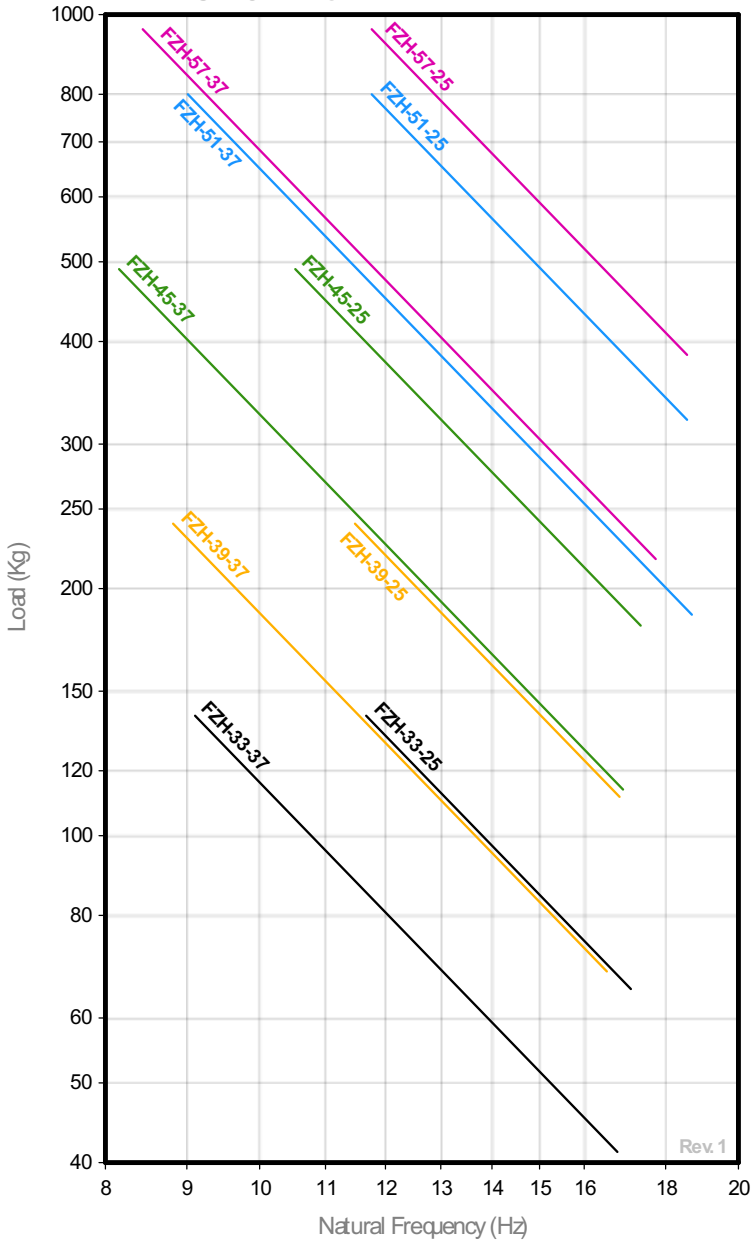

LOAD DEFLECTION GRAPH  
FZH + SYLOMER®

