

AKUSTIK + **AMC**
MECANOCAUCHO

AKUSTIK + **sylomer**^{by getzner}

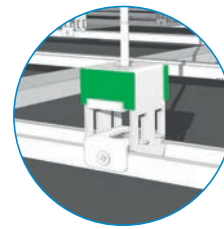

AMC
MECANOCAUCHO



Noise isolation ceiling



FZ + Sylomer®

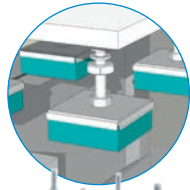

TSR + Sylomer®

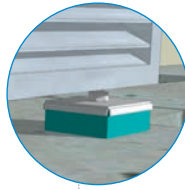

SRB & SRS + Sylomer®



Grand Akustik



Springtec & Springtec Super



Akustik + Sylomer®

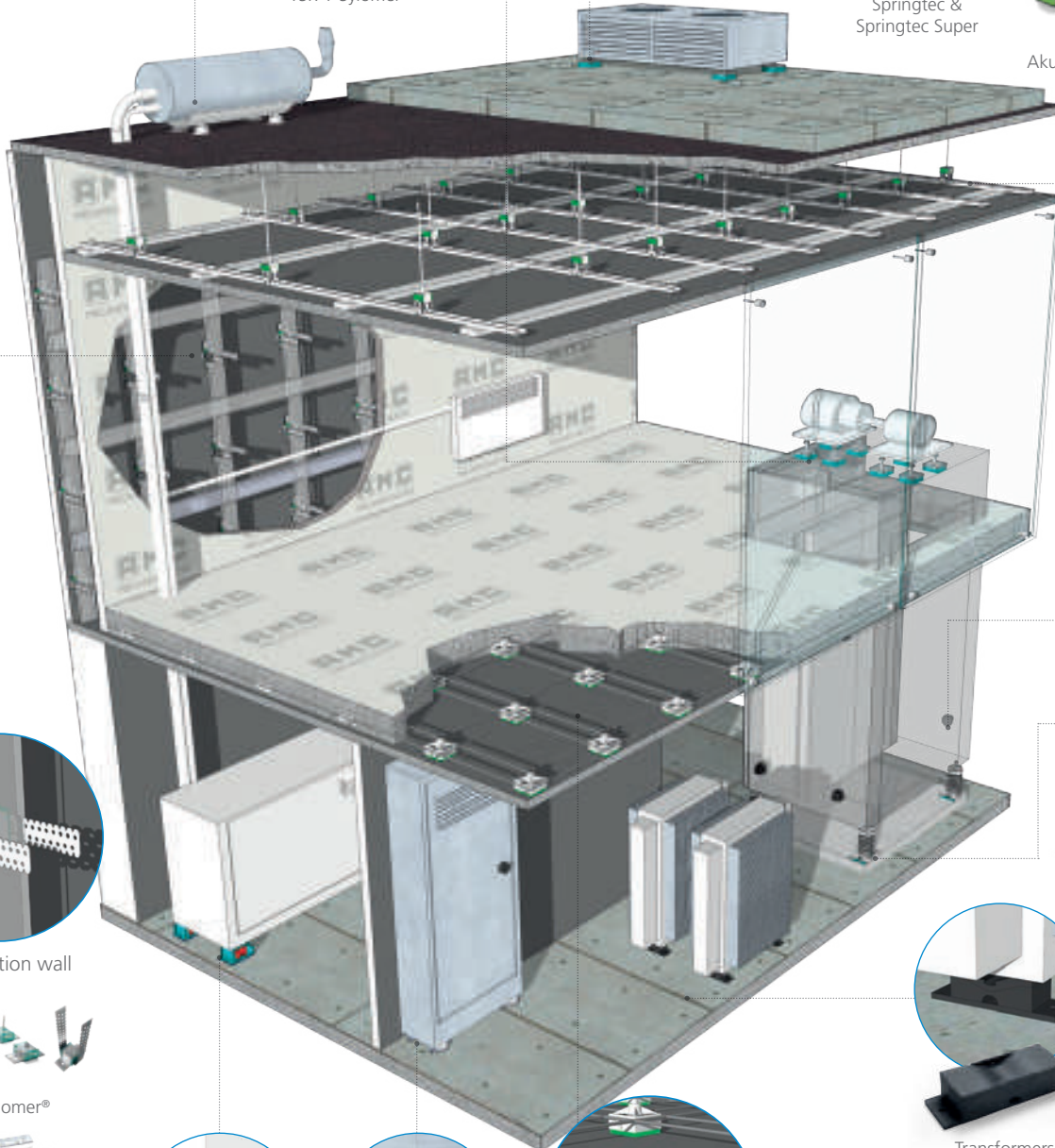

SCB

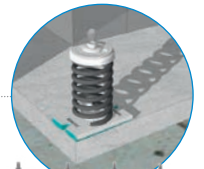

Vibrabsorber + Sylomer®

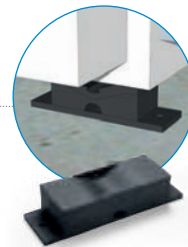

Transformers

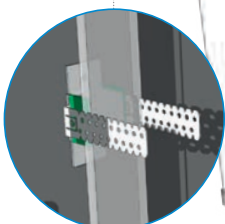

Noise isolation wall



EP+Sylomer®



EP



4 AMC Seismic + Sylomer®



BRB

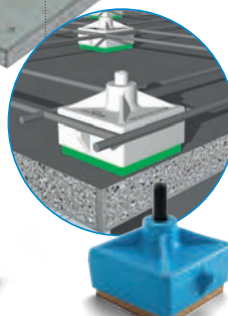

FZH + Sylomer®

Noise isolation floor

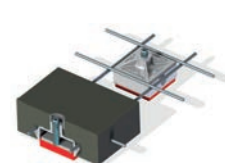

PRESENTATION Page 04

AKUSTIK + MECANOCAUCHO

Basic information on structural acoustics Page 07

ACOUSTIC HANGERS

Akustik Page 09

Gran Akustik Page 12

Springtec Page 13

VT Page 15

Spring Rubber Page 19

ACOUSTIC WALL TIES

E.P. Page 21

FLOATING FLOOR MOUNTS

BF Floating floor mounts Page 23

G Floating floor mounts Page 24

Tabiabsorber Page 25

AKUSTIK + by getzner

Comparative tests at the Labein technology centre Page 27

Behaviour at high and low frequencies Page 31

ACOUSTIC HANGERS

Akustik + Sylomer® Page 32

Gran Akustik + Sylomer® Page 42

SRS + Sylomer® Page 49

ACOUSTIC WALL TIES

EP + Sylomer® Page 52

FLOATING FLOOR MOUNTS

TSR + Sylomer® Page 56

FHZ + Sylomer® Page 59

ANTI VIBRATION MOUNTS

TLG + Sylomer® Page 63



Factory 1 of AMC-MECANOCAUCHO



Factory 2 of AMC-MECANOCAUCHO



Factory of **sylomer** in Austria.



Akustik+Sylomer® is the trademark of a new solution for the anti-vibration mountings of false ceilings or vibrating elements that have to be suspended. They are used for the attenuation of vibrations, reducing structure-borne noise.

AMC-MECANOCAUCHO® has been manufacturing anti-vibration suspensions since 1969, and since then it has been manufacturing suspensions for this same purpose, using rubber, spring or a combination of both, called **Akustik**.

GETZNER Werkstoffe GmbH manufactures a prestigious anti-vibration material called **Sylomer®** whose main application has been the isolation of vibrations produced by railways. Operating from Austria since 1969, it is now the leader in its sector, and boasts totally cutting-edge technological facilities and media for vibration isolation.

The **Akustik+Sylomer®** ceiling mounts are made of Sylomer®, a microcelular polyurethane material specially conceived for vibration isolation. This material produces a higher degree of damping than the elastomers traditionally used for this purpose.

ENGINEERING

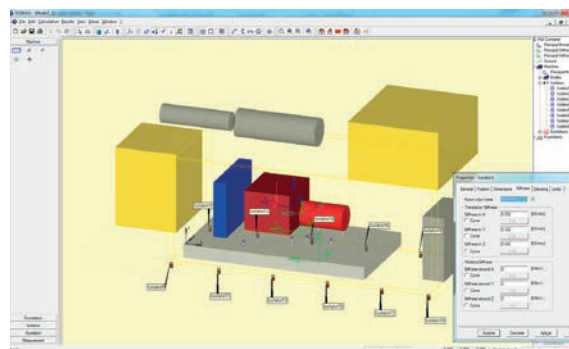

LOGISTICS



| | |
|--|-------|
| | 24 h. |
| | 48 h. |
| | 72 h. |

ANTIVIBRATION CALCULATIONS

| Nº | Modelo | Descripción | Altura | Material | Resorte | Constante | Deflexión | Deflexión | Deflexión |
|----|---------|---------------------------|--------|----------|---------|-----------|-----------|-----------|-----------|
| 1 | 1381273 | MECANOCAUCHO Tipo B88 150 | 1000.0 | 0 | 0.000 | 1000.0000 | 0.7627 | 65.0140 | 0.0000 |
| 2 | 1381273 | MECANOCAUCHO Tipo B88 150 | 1000.0 | 170.000 | 0.000 | 1104.7011 | 0.8477 | 67.2047 | 0.0000 |
| 3 | 1381273 | MECANOCAUCHO Tipo B88 150 | 1000.0 | 220.000 | 0.000 | 1146.0000 | 0.1230 | 08.3000 | 0.0000 |
| 4 | 1381273 | MECANOCAUCHO Tipo B88 150 | 1000.0 | 240.000 | 0.000 | 1170.0000 | 0.2803 | 09.7000 | 0.0000 |
| 5 | 1381273 | MECANOCAUCHO Tipo B88 150 | 1000.0 | 240.000 | 0.000 | 1170.0000 | 0.2803 | 09.7000 | 0.0000 |
| 6 | 1381273 | MECANOCAUCHO Tipo B88 150 | 1000.0 | 220.000 | 0.000 | 1146.0000 | 0.1230 | 08.3000 | 0.0000 |
| 7 | 1381273 | MECANOCAUCHO Tipo B88 150 | 1000.0 | 170.000 | 0.000 | 1104.7011 | 0.8477 | 67.2047 | 0.0000 |
| 8 | 1381273 | MECANOCAUCHO Tipo B88 150 | 1000.0 | 0 | 0.000 | 1000.0000 | 0.7627 | 65.0140 | 0.0000 |

Resorte: 0.0000 N
 Resorte: 0.0000 N
 Deflexión: 0.07

Deflexión: 0.07 m
 Deflexión: 0.07 m
 Deflexión: 0.07 m

EXPOSITION TOOLS FOR DISTRIBUTORS

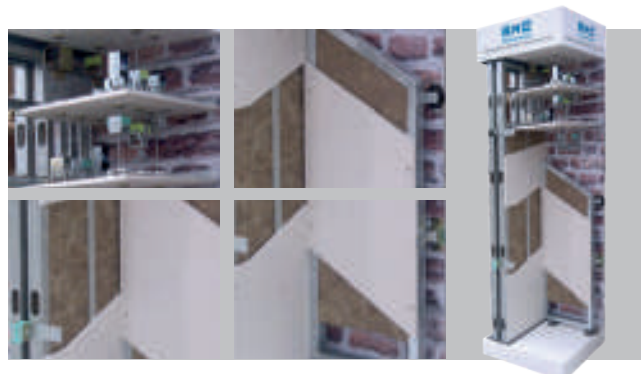

The cooperation of two great companies

QUALITY

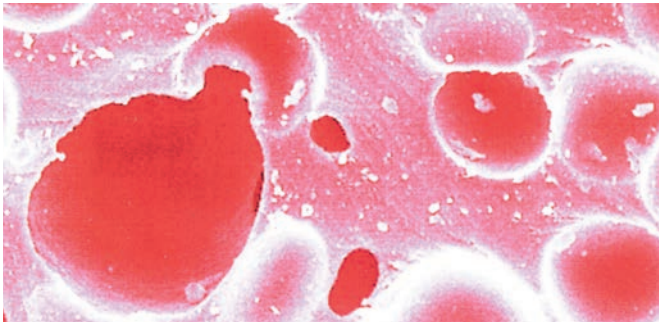

We have more than 45 years of experience providing quality products, capable of overcoming the most demanding tests. For this purpose it is vital our knowledge on the correct manufacturing processes and the use first grade components.

SERVICE



We keep in stock more than 4,5 Million euros of finished products. This fact is key to respond quick to urgent enquiries.

ENGINEERING SERVICES



Calculations • Development • Tests • Measurements

Our technical department makes calculations, develops new products, analyzes their elastical properties and make on site measurements in order to find the correct technical solution to solve each vibration problem.

DISTRIBUTOR SUPPORT



AMC-MECANOCAUCHO offers a wide range of exposition displays on store. Should you require one, do not hesitate to contact our sales dpt, so they can offer you the one that adapts better to your needs.

Akustik+ MECANOCAUCHO

Reliability and cost effectiveness

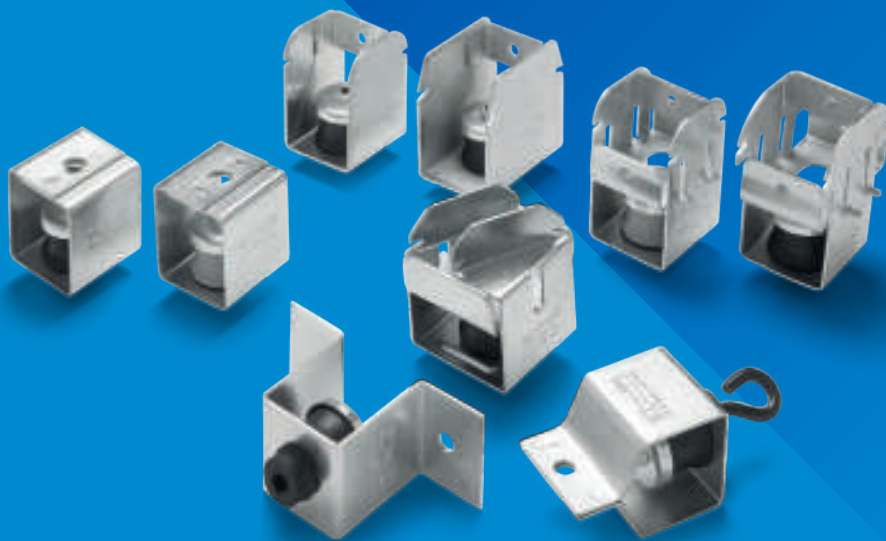

AKUSTIK+ AMC Mekanocaucho[®]

ACOUSTIC HANGERS

BASIC INFORMATION ON STRUCTURAL ACOUSTICS

1.- NOISE AND VIBRATION PROBLEMS IN PREMISES

Sound that is unpleasant to the human ear is known as noise, and ecologically speaking is a form of pollution that is becoming increasingly more widespread due to town and city development.

It could be defined as a vibratory phenomenon propagated in an elastic medium (ceilings, walls, floors and the air itself) causing perturbations in it. To isolate any premises or venue properly, the first step is to identify the composition and the values of the noise (spectrum of frequencies, noise level etc.).

Once we know the magnitude of the noise or the vibrations to be insulated, we must built an unconnected off-the-floor frame which gives us the insulating and dampening values we need.

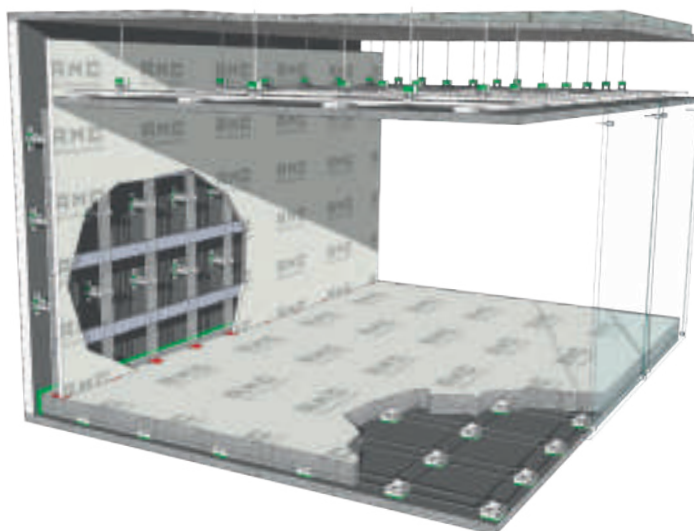

2.- BOX-IN-BOX Concept

The "box in box" concept consists of acoustically isolating a room by placing flexible elements between the structure of the building and the elements that can be seen and are in direct contact with people.

AMC-MECANOCAUCHO offers a wide range of mounts for noise and vibration isolation of floors, ceilings and walls. There are solutions available with rubber technology, Sylomer[®], springs or a combination of them.



3.- ANTI VIBRATION SOLUTIONS

| | | |
|--|--|---|
| <p>A. RUBBER Natural frequency between 10-15Hz. Effective in medium and high frequencies. Small static deflections. High dampening.</p> |  |  |
| <p>B. SYLOMER[®] Natural frequency between 7-12Hz. Effective in medium and high frequencies. Very small static deflections.</p> |  |  |
| <p>C. SPRING Natural frequency between 2-7Hz. Effective in low and medium frequencies. Large static deflections. Same static and dynamic behavior. Low dampening, excellent isolation.</p> |  |  |

BASIC INFORMATION ON STRUCTURAL ACOUSTICS

4.- THE IMPORTANCE OF THE DYNAMIC FREQUENCY OF THE ANTIVIBRATION MOUNTS.

Real data are required to carry out a study and calculation of a premises.

The static stiffnesses that are provided by static load-deflection graphs are not valid for the calculation of a realistic insulation. Experience shows that the static calculations are very different from reality.

At the moment, AMC has a dynamic testing machine that can generate the most common types of vibration on premises, giving real frequency values, insulation, loss angle and critical dampening rate.

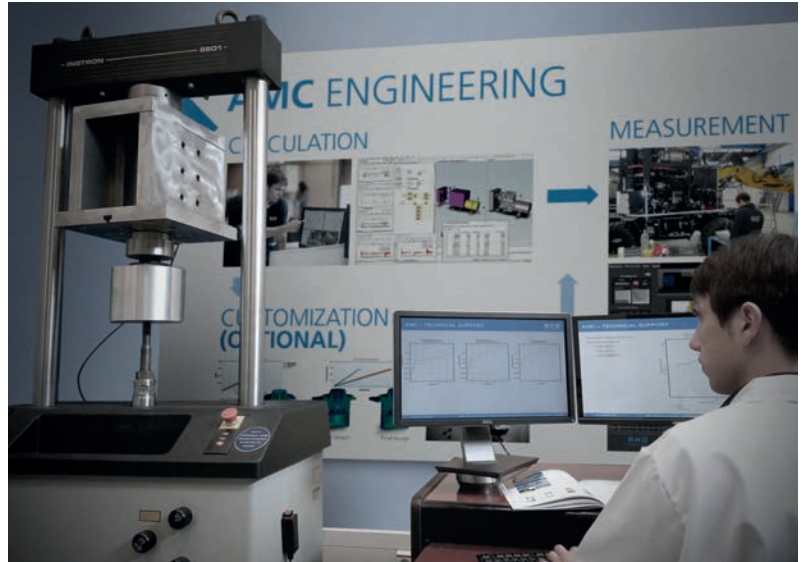

Dynamic testing machine

5.- INSTALLATION, 50% OF THE SOLUTION. OUR ADVICE: INSTALLATION OF PERIMETER SEAL.

The correct installation of these mounts is a critical factor to obtain optimal results of acoustical isolation. To achieve this, it is important to make a proper perimeter sealing, in order to avoid acoustic bridges that could lead to the transmission of noise through the walls.

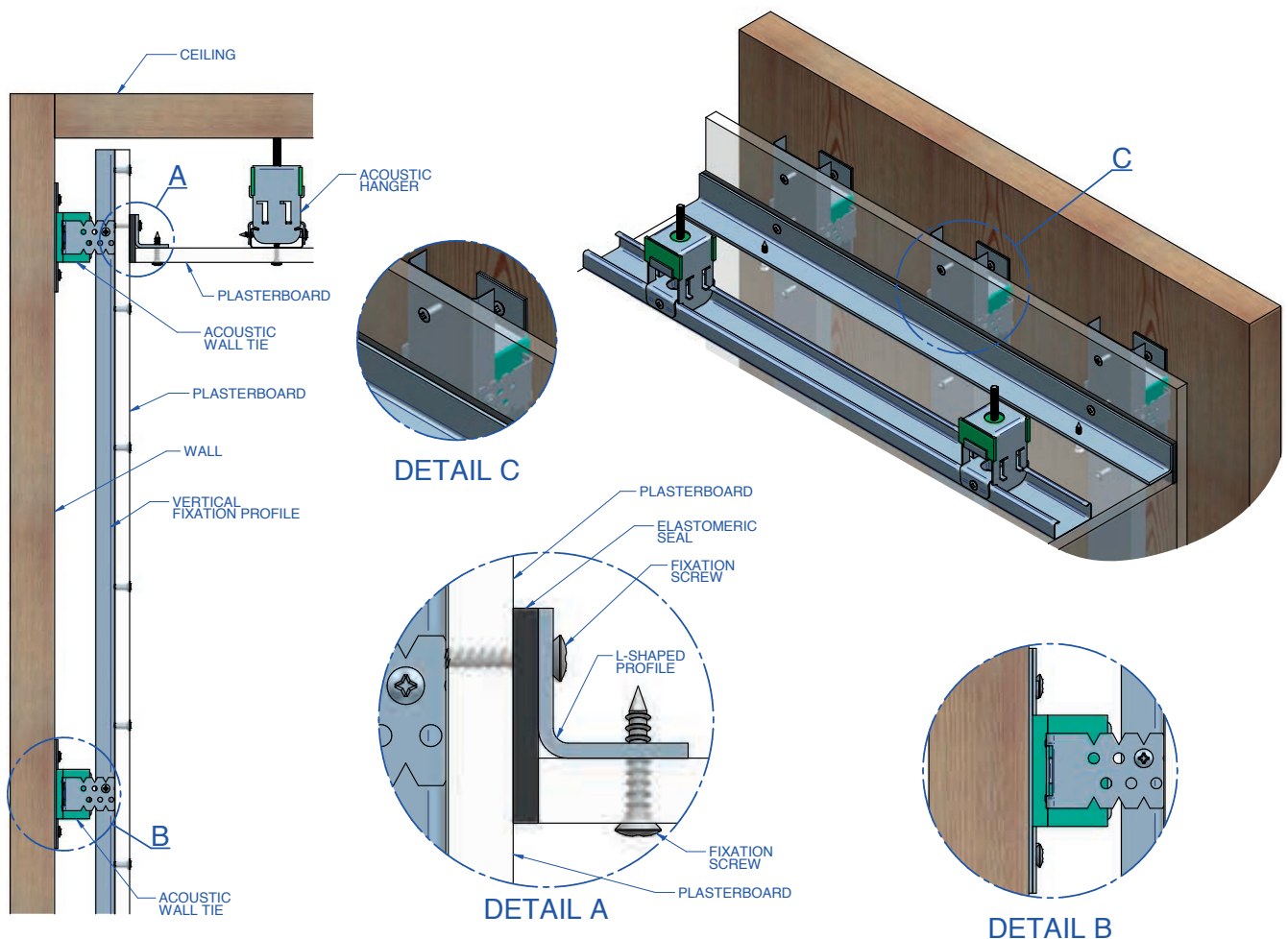

AKUSTIK+ AMC Mecnocaucho[®]

ACOUSTIC HANGERS

Akustik Range



A-45 Loads from 8 to 30 kg B-60 Loads from 25 to 60 kg

Range designed for suspension of false acoustic ceilings and machinery operating at more than 1.000 r.p.m. The same vibration damping element which is used throughout the Akustik range is made of rubber of high mechanical performance; it is specially designed for vibration damping. The metallic structure is designed to resist loads up to 650 kg. It is supplied with an anti-corrosive zinc-plated coat.

Dynamic behaviour

GRAPH 1
Static load deflection graph

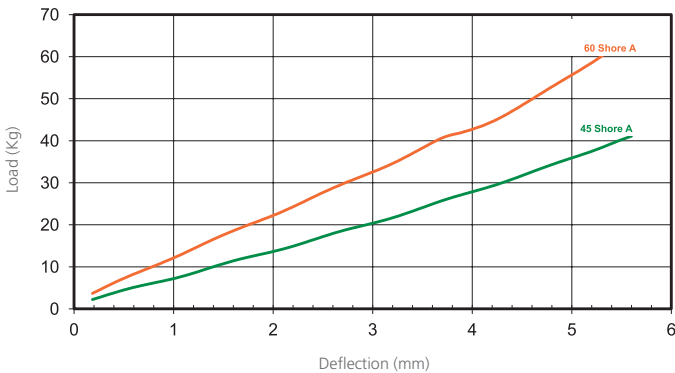

GRAPH 2
Natural frequency graph

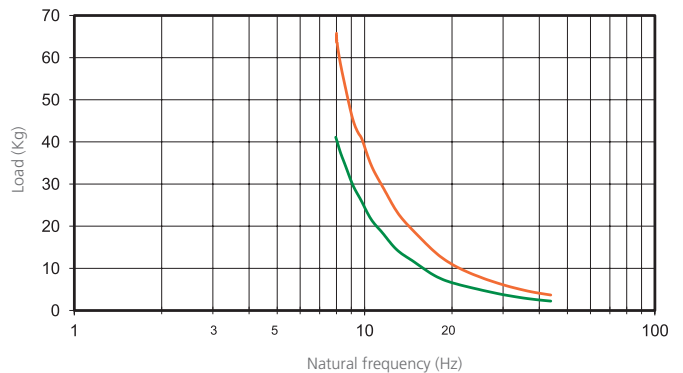

To select correct mounting, following data are needed:

- Load per mounting (kg).
- Disturbing frequency (Hz).

Select correct load line in diagram 1 and refer to diagram 2 to obtain the Natural frequency. With this natural frequency prolong this line to the diagram 3 and obtain the % of isolation at the given Excitation Frequency (Hz).

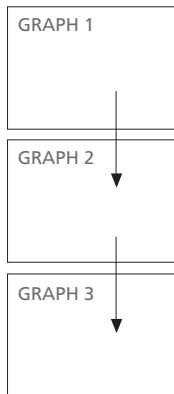

GRAPH 3
% of isolation and attenuation in dB

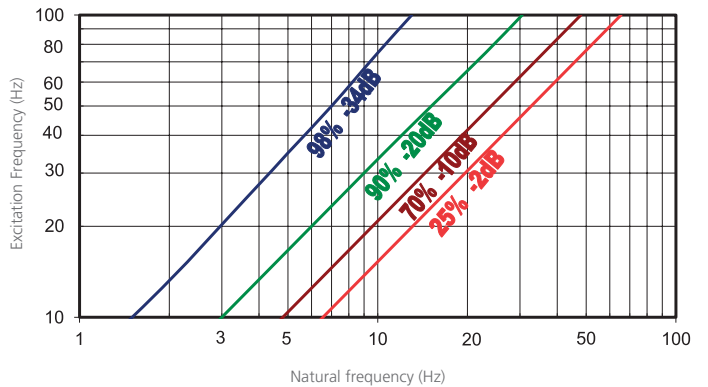

| | REF. AMC | LOAD | CODE |
|--|-------------------------|-----------|-------|
| | Akustik Super T-47 A-45 | 8-30 Kg. | 23801 |
| | Akustik Super T-47 B-60 | 25-60 Kg. | 23802 |

| | REF. AMC | LOAD | CODE |
|--|-------------------------|-----------|-------|
| | Akustik Super T-60 A-45 | 8-30 Kg. | 23811 |
| | Akustik Super T-60 B-60 | 25-60 Kg. | 23812 |

| | REF. AMC | LOAD | CODE |
|--|---------------------|-----------|-------|
| | Akustik Sierra A-45 | 8-30 Kg. | 23861 |
| | Akustik Sierra B-60 | 25-60 Kg. | 23862 |

ACOUSTIC HANGERS

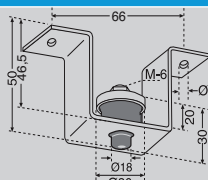
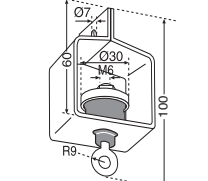
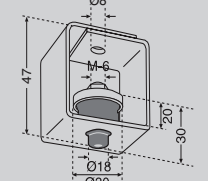
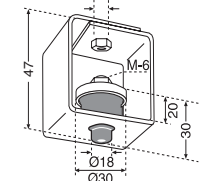
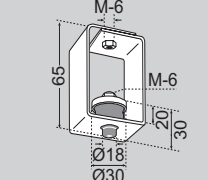
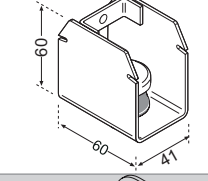
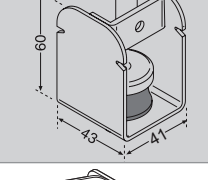
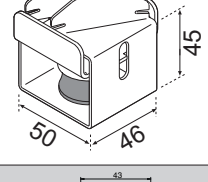
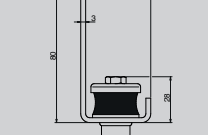
| REF. AMC | LOAD | CODE | SUMMARY |
|---|----------|-------|---|
|  | 8-30 Kg | 23101 | Fitted directly to ceiling using two holes. |
|  | 8-30 Kg | 23111 | Anchoring to the ceiling with hooks. |
|  | 8-30 Kg | 23121 | Fitted by using an M-6 rod and a nut. |
|  | 8-30 Kg | 23131 | Fitted to ceiling using an M-6 rod. |
|  | 8-30 Kg | 23133 | Fitted to ceiling using an M-6 rod. |
|  | 8-30 Kg | 23143 | Fitted to ceiling using an M-6 rod. |
|  | 8-30 Kg | 23145 | Designed for easy and accesible fitting together with great strenght. |
|  | 8-30 Kg | 23210 | The rotational system of the part assures the correct installation thanks to the design of the metal part at 45°. |
|  | 8-30 Kg. | 23103 | Designed for vertical plane fitting |

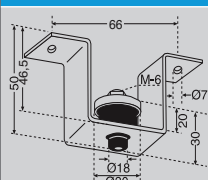
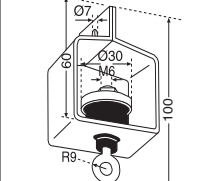
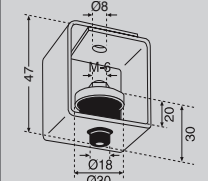
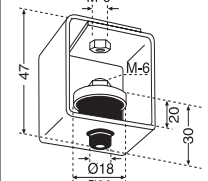
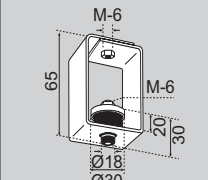
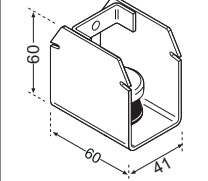
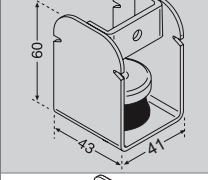
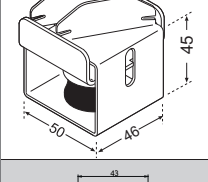
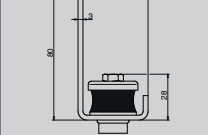
| REF. AMC | LOAD | CODE | SUMMARY |
|--|-----------|-------|---|
|  | 25-60 Kg | 23102 | Fitted directly to ceiling using two holes. |
|  | 25-60 Kg | 23112 | Anchoring to the ceiling with hooks. |
|  | 25-60 Kg | 23122 | Fitted by using an M-6 rod and a nut. |
|  | 25-60 Kg | 23132 | Fitted to ceiling using an M-6 rod. |
|  | 25-60 Kg | 23134 | Fitted to ceiling using an M-6 rod. |
|  | 25-60 Kg | 23144 | Fitted to ceiling using an M-6 rod. |
|  | 25-60 Kg | 23146 | Designed for easy and accesible fitting together with great strenght. |
|  | 25-60 Kg | 23213 | The rotational system of the part assures the correct installation thanks to the design of the metal part at 45°. |
|  | 25-60 Kg. | 23104 | Designed for vertical plane fitting |

AKUSTIK+ AMC Mecanocaucho®

ACOUSTIC HANGERS

Akustik Range

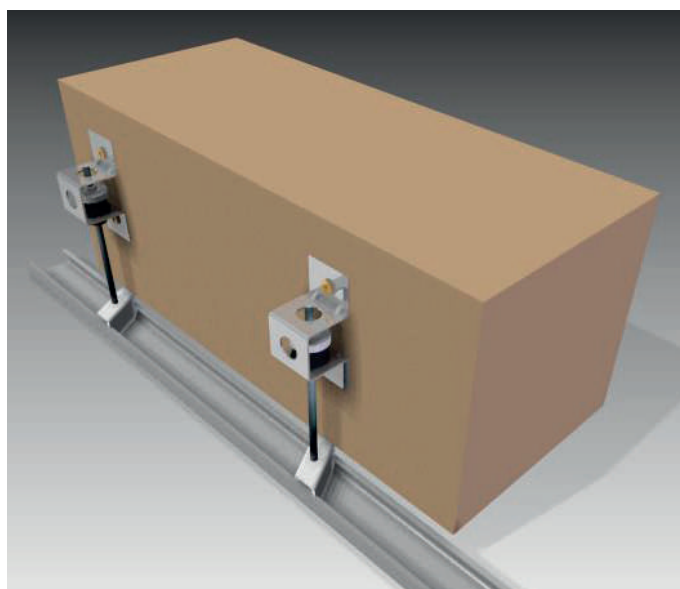
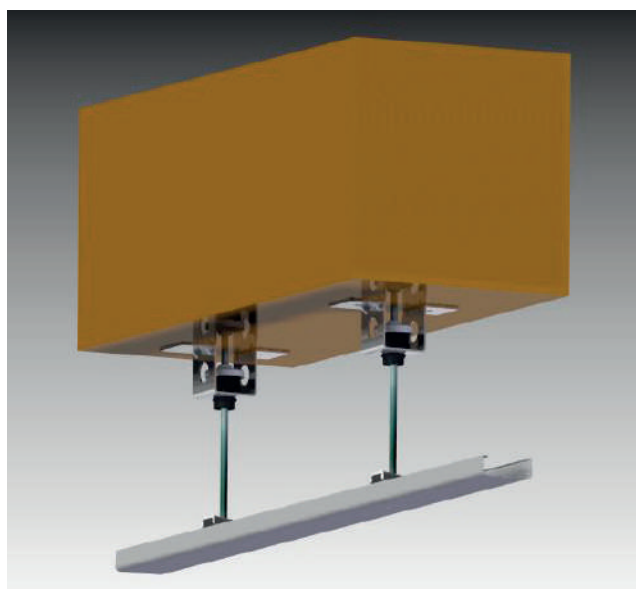
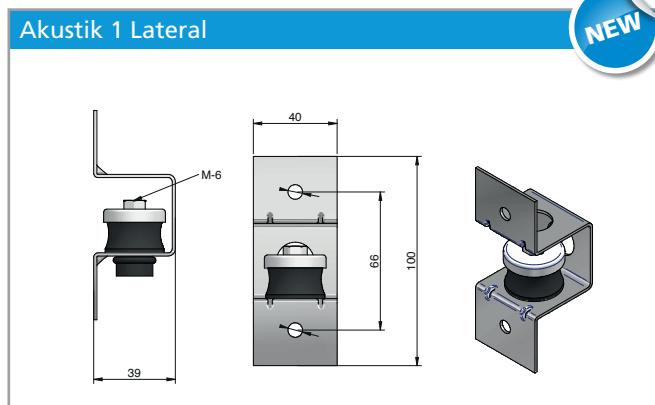
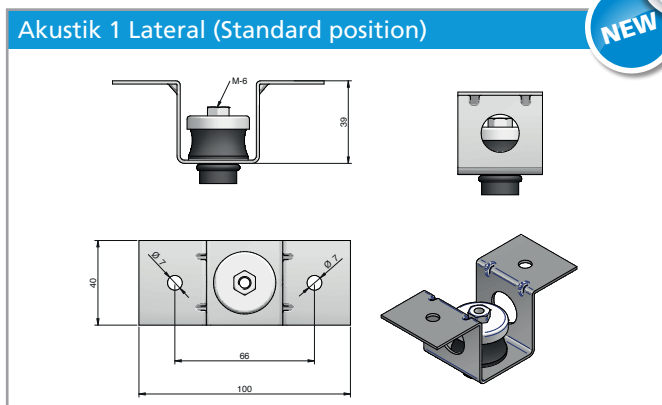

| REF. AMC | LOAD | CODE |
|------------------------|----------|-------|
| Akustik 1 Lateral A-45 | 8-30 Kg | 23571 |
| Akustik 1 Lateral B-60 | 25-60 Kg | 23572 |

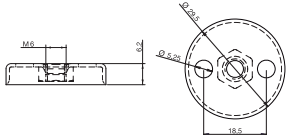
| REF. AMC | LOAD | CODE |
|--|----------------|-------|
|  | Levelling bell | 23159 |

Steps of the installation for the Akustik Safety

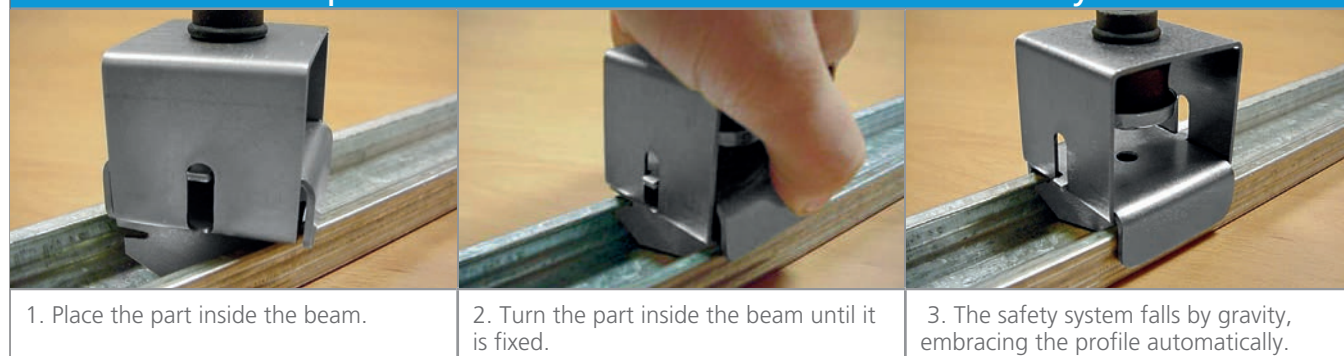

1. Place the part inside the beam.

2. Turn the part inside the beam until it is fixed.

3. The safety system falls by gravity, embracing the profile automatically.

ACOUSTIC HANGERS

Grand Akustik range

A-45 load from 40 to 100 kg

B-60 load from 80 to 150 kg

Range designed for suspension of false acoustic ceilings and machinery operating at more than 1.000 r.p.m. The same antivibration element is used for all the range. This element is made of rubber offering high mechanical performance and it is specially studied for vibratory insulation. The metallic structure is designed to resist loads up to 1000 Kg. It is supplied with an anticorrosive zinc-plated coat.



Dynamic behaviour

GRAPH 1
Static load deflection graph

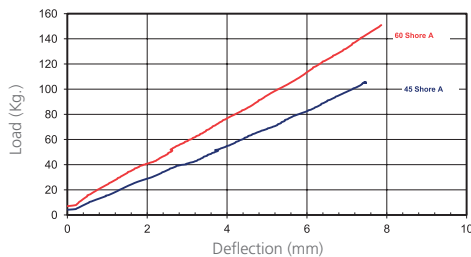

GRAPH 2
Natural frequency (Hz)

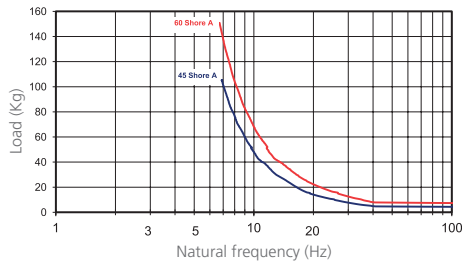

GRAPH 3
% of isolation and attenuation in dB

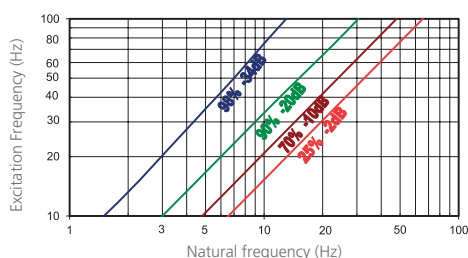

| | REF. AMC | LOAD | CODE |
|--|----------------------|------------|-------|
| | Grand Akustik 1 A-45 | 40-100 Kg. | 23201 |
| | Grand Akustik 2 A-45 | 40-100 Kg. | 23211 |
| | Grand Akustik 3 A-45 | 40-100 Kg. | 23221 |
| | Grand Akustik 1 B-60 | 80-150 Kg. | 23202 |
| | Grand Akustik 2 B-60 | 80-150 Kg. | 23212 |
| | Grand Akustik 3 B-60 | 80-150 Kg. | 23222 |



Grand Akustik 3



Grand Akustik 2



Example of installation

AKUSTIK+ AMC Mecanocaucho[®]

ACOUSTIC HANGERS

Springtec range

Load from 5 to 60 kg.

Range designed for suspensions of false acoustic ceilings and machinery working at more than 450 r.p.m. Manufactured with piano tail quality spring of great mechanical resistance guided by two rubber plates with integral end stops to prevent contact between spirals when overloading.



Dynamic behaviour

GRAPH 1

Static load deflection graph

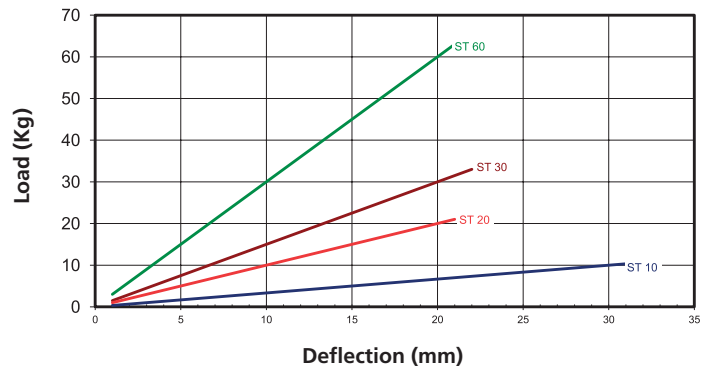

GRAPH 2

Natural frequency (Hz)

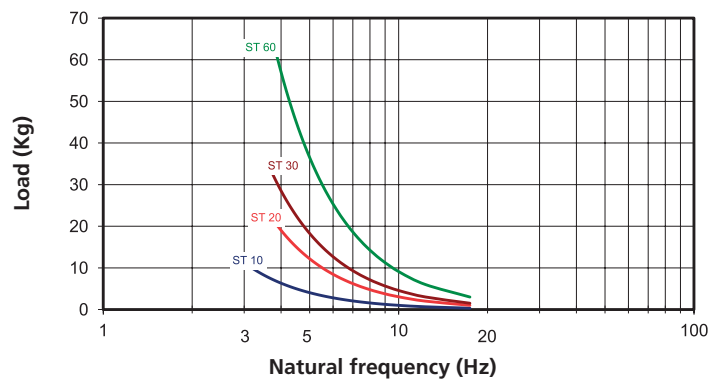

GRAPH 3

% of isolation and attenuation in dB

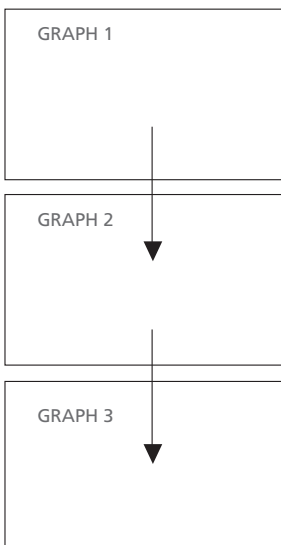
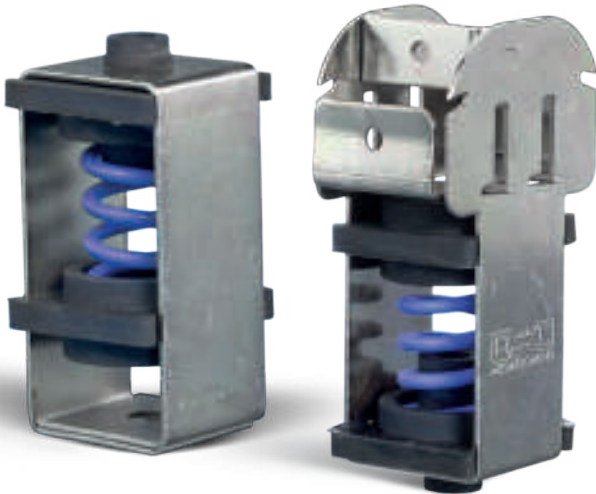
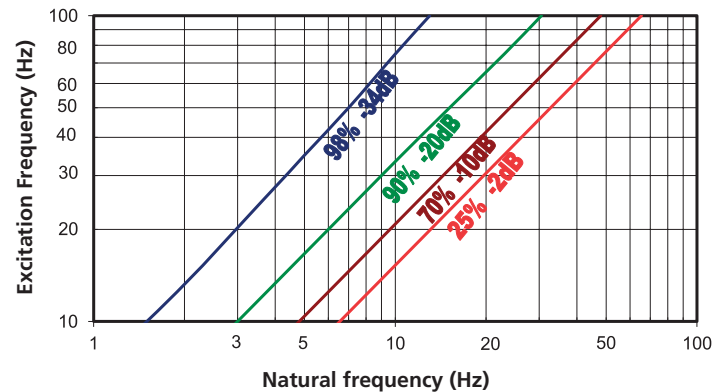

To select correct mounting, following data are needed:

- Load per mounting (kg).
- Disturbing frequency (Hz).

Select correct load line in diagram 1 and refer to diagram 2 to obtain the Natural frequency. With this natural frequency prolong this line to the diagram 3 and obtain the % of isolation at the given Excitation Frequency (Hz).

ACOUSTIC HANGERS

Springtec ceiling hanger

| | LOAD AMC | MAX. PERMANENT LOAD | LOAD |
|--|-------------------------|---------------------|-------|
| | Springtec ST-10 Type 1 | 10 Kg. | 23301 |
| | Springtec ST-20 Type 1 | 20 Kg. | 23302 |
| | Springtec ST-30 Type 1 | 30 Kg. | 23303 |
| | Springtec ST-60 Type 1 | 60 Kg. | 23304 |
| | Springtec ST-10 Type 2 | 10 Kg. | 23305 |
| | Springtec ST-20 Type 2 | 20 Kg. | 23307 |
| | Springtec ST-30 Type 2 | 30 Kg. | 23309 |
| | Springtec ST-60 Type 2 | 60 Kg. | 23311 |
| | Springtec ST-10 Lateral | 10 Kg. | 23406 |
| | Springtec ST-20 Lateral | 20 Kg. | 23407 |
| | Springtec ST-30 Lateral | 30 Kg. | 23408 |
| | Springtec ST-60 Lateral | 60 Kg. | 23409 |

| | LOAD AMC | MAX. PERMANENT LOAD | LOAD |
|--|---------------------------------|---------------------|-------|
| | Springtec Super T-47 Type ST-10 | 10 Kg. | 23421 |
| | Springtec Super T-47 Type ST-20 | 20 Kg. | 23422 |
| | Springtec Super T-47 Type ST-30 | 30 Kg. | 23423 |
| | Springtec Super T-47 Type ST-60 | 60 Kg. | 23424 |
| | Springtec Super T-60 Type ST-10 | 10 Kg. | 23351 |
| | Springtec Super T-60 Type ST-20 | 20 Kg. | 23352 |
| | Springtec Super T-60 Type ST-30 | 30 Kg. | 23353 |
| | Springtec Super T-60 Type ST-60 | 60 Kg. | 23354 |



AKUSTIK+ AMC Mekanocaucho[®]

ACOUSTIC HANGERS

VT ceiling hanger

Load from 10 to 750 kg

Range designed for suspension of false acoustic ceilings and machinery operating at more than 450 r.p.m. These isolators are made of piano tail spring quality with a high mechanical performance. They incorporate rubber bush

conceived to avoid the "acoustic bridges" and the contact of a non aligned screw. The metallic structure is very robust and it is supplied with an anti-corrosive zinc-plated coat.

Dynamic behaviour

GRAPH 1

LOAD DEFLECTION CURVES
VT 15 - VT 150R HANGERS

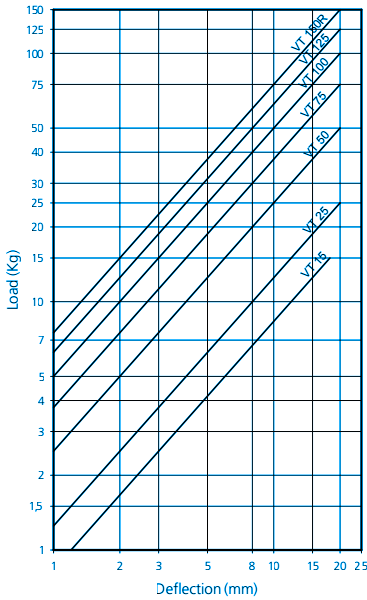

GRAPH 1

LOAD DEFLECTION CURVES
VT 150 - VT 750 HANGERS

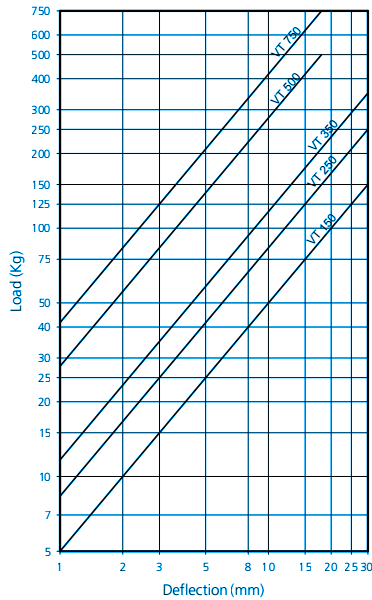

GRAPH 3

% of isolation and attenuation in dB

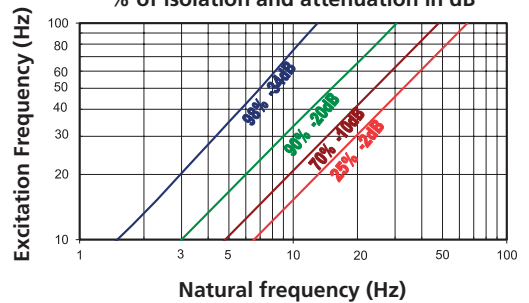

GRAPH 2

NATURAL FREQUENCY CURVES
VT 15 - VT150R HANGERS

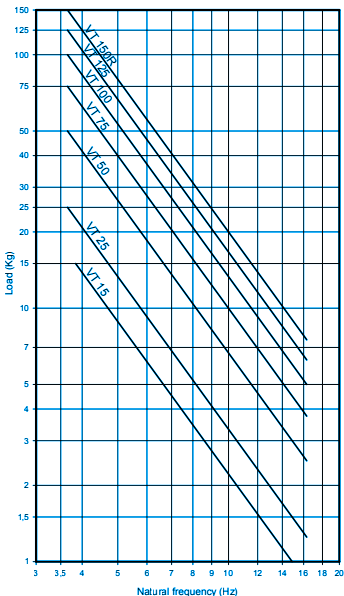

GRAPH 2

NATURAL FREQUENCY CURVES
VT 150 - VT 750 HANGERS

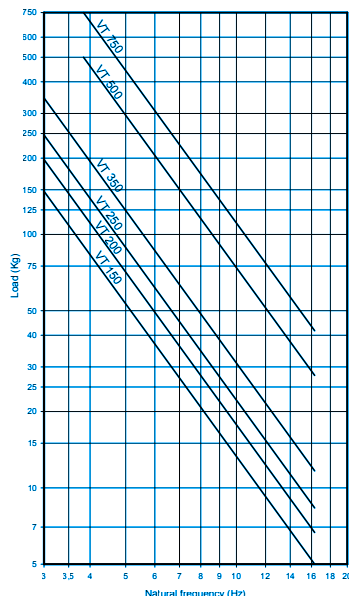

To select correct mounting, following data are needed:

- Load per mounting (kg).
- Disturbing frequency (Hz).

Select correct load line in diagram 1 and refer to diagram 2 to obtain the Natural frequency. With this natural frequency prolong this line to the diagram 3 and obtain the % of isolation at the given Excitation Frequency (Hz).

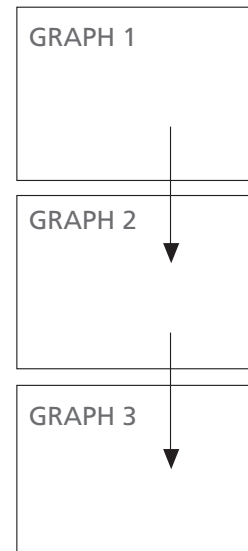

ACOUSTIC HANGERS

VT ceiling hanger

| | Type | MAX PERMANENT LOAD | Spring color | A (mm) | C (mm) | E (mm) | H(mm) | M | Weight (kg) | Code |
|--|---------|--------------------|--------------|--------|--------|--------|-------|------|-------------|--------------|
|  | VT 15 | 15 | BLACK | 80 | 12 | 50 | 120 | M-8 | 0,71 | 20200 |
| | VT 25 | 25 | BLACK | 25 | 12 | 50 | 120 | M-8 | 0,71 | 20201 |
| | VT 50 | 50 | BLUE | 50 | 12 | 50 | 120 | M-8 | 0,7 | 20202 |
| | VT 75 | 75 | GREY | 75 | 12 | 50 | 120 | M-8 | 0,72 | 20203 |
| | VT 100 | 100 | BEIGE | 100 | 12 | 50 | 120 | M-8 | 0,778 | 20204 |
| | VT 125 | 125 | WHITE | 125 | 12 | 50 | 120 | M-8 | 1,102 | 20211 |
| | VT 150R | 150 | BLACK | 80 | 12 | 50 | 120 | M-8 | 0,77 | 20224 |
| | VT 150 | 150 | BLUE | 150 | 16 | 80 | 160 | M-12 | 2,035 | 20205 |
| | VT 200 | 200 | WHITE | 200 | 16 | 80 | 160 | M-12 | 2,072 | 20210 |
| | VT 250 | 250 | BLACK | 250 | 16 | 80 | 160 | M-12 | 2,148 | 20206 |
| | VT 350 | 350 | CREAM | 350 | 16 | 80 | 160 | M-12 | 2,33 | 20207 |
| | VT 500 | 500 | LIGHT GREY | 500 | 18 | 100 | 180 | M-14 | 4,785 | 20208 |
| | VT 750 | 750 | GREEN | 750 | 18 | 100 | 180 | M-14 | 5,249 | 20209 |

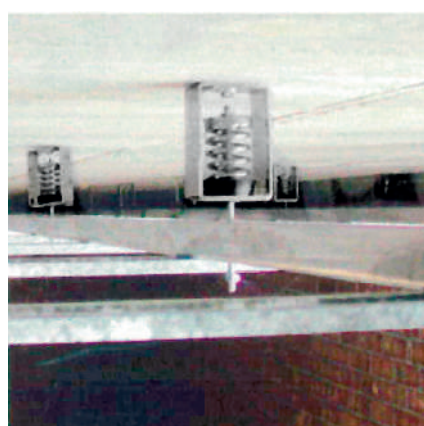

AKUSTIK+ AMC Mecanocaucho[®]

VT-HD

APPLICATIONS

AMC-MECANOCAUCHO[®] VT HD Hangers, due to their low stiffness, are able to reach natural frequencies from 2 to 5Hz, and are specially suitable for applications where high isolation level is required.

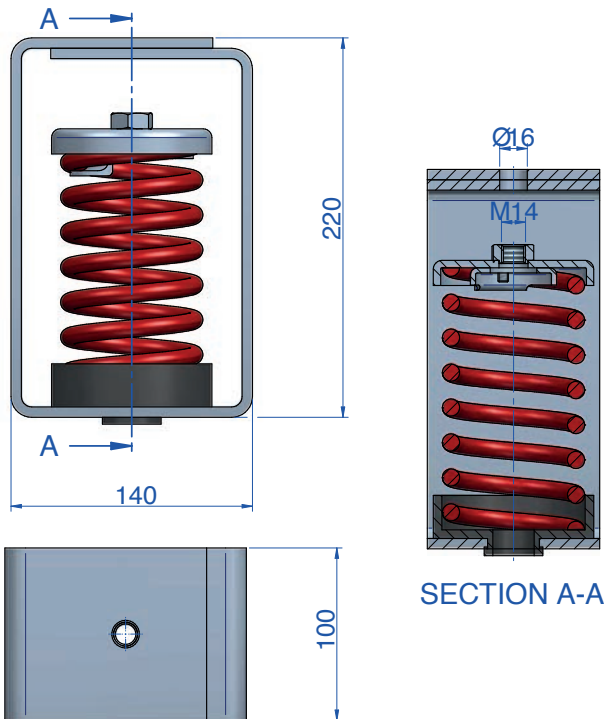

| Type | MAX PERMANENT LOAD | Spring color | DEFLECTION mm | Code |
|-----------|--------------------|--------------|---------------|-------|
| VT-67 HD | 67 | BLUE | 50 | 20235 |
| VT-95 HD | 95 | WHITE | 50 | 20239 |
| VT-123 HD | 123 | BLACK | 50 | 20236 |
| VT-173 HD | 173 | BEIGE | 50 | 20240 |
| VT-223 HD | 223 | RED | 50 | 20237 |
| VT-335 HD | 335 | GREY | 50 | 20241 |
| VT-446 HD | 446 | GREEN | 50 | 20238 |

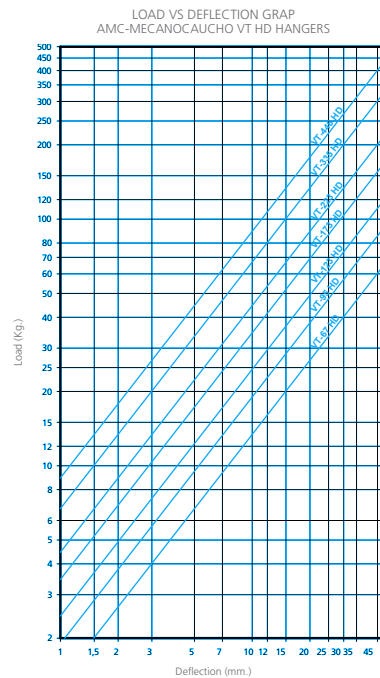
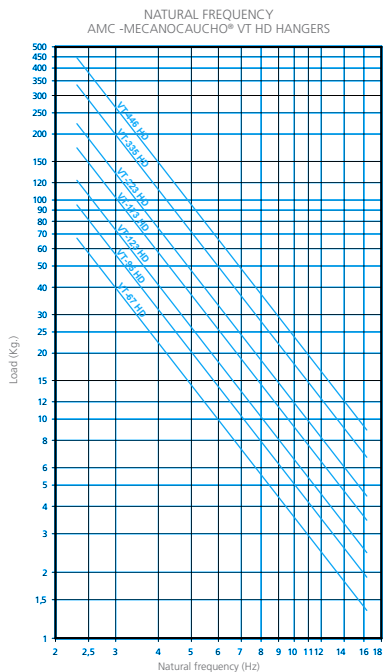

ACOUSTIC HANGERS

VT 3

APPLICATIONS

The VT type 3 Low natural frequency acoustic hangers are produced as standard on 6 different stiffness coil springs to suit loads per point from 5 up to 150 Kg. The natural frequency on their optimal loading point ranges below 5 Hz. These technical properties provide a high level of noise and vibration isolation on light concrete structures. Their metal parts are coated to withstand corrosive environments.

They are typically installed every 1,5 linear meter. But this feature may be tuned in order to adapt to the load or natural frequency requirement of the application.

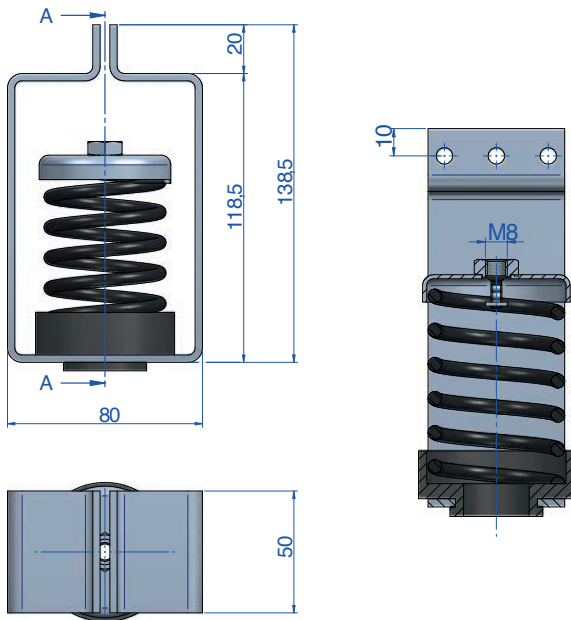

| Type | Spring color | Max. Load (kg) | Code |
|--------|--------------|----------------|-------|
| VT 25 | BLACK | 25 | 20218 |
| VT 50 | BLUE | 50 | 20219 |
| VT 75 | GREY | 75 | 20220 |
| VT 100 | BEIGE | 100 | 20221 |
| VT 125 | WHITE | 125 | 20222 |
| VT 150 | BLACK | 150 | 20217 |

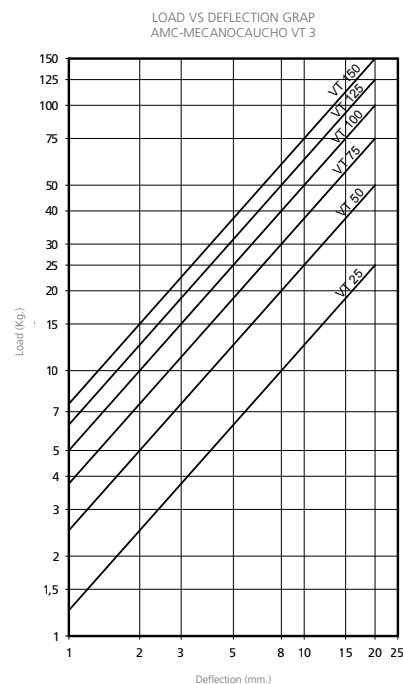
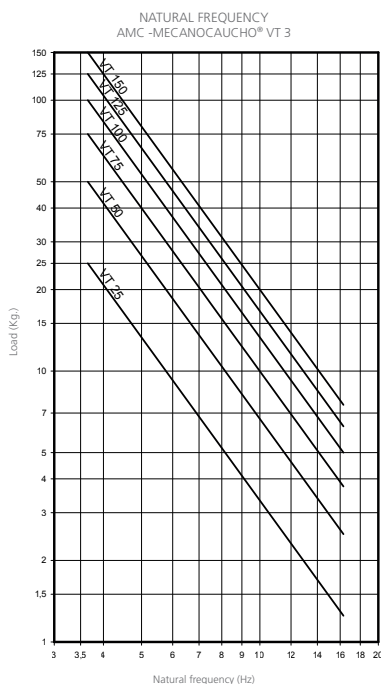

AKUSTIK+ AMC Mekanocaucho[®]

ACOUSTIC HANGERS

Spring Rubber[®] ceiling hanger

Load from 8 to 100 kg.

This is a new range of anti-vibration mounts, combining the high deflection of the spring with the dampening properties of the rubber. The metallic structure is very robust and it is supplied with an anticorrosive zinc-plated coat.



Dynamic behaviour

To select correct mounting, following data are needed:

- Load per mounting (kg).
- Disturbing frequency (Hz).

Select correct load line in diagram 1 and refer to diagram 2 to obtain the Natural frequency. With this natural frequency prolong this line to the diagram 3 and obtain the % of isolation at the given Excitation Frequency (Hz).

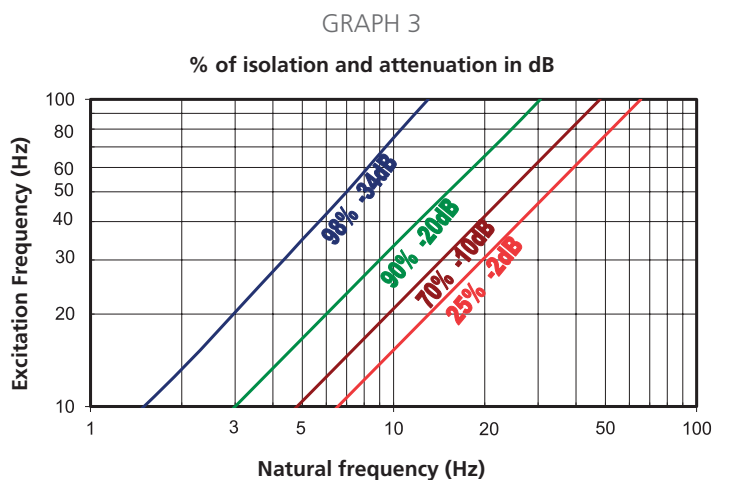
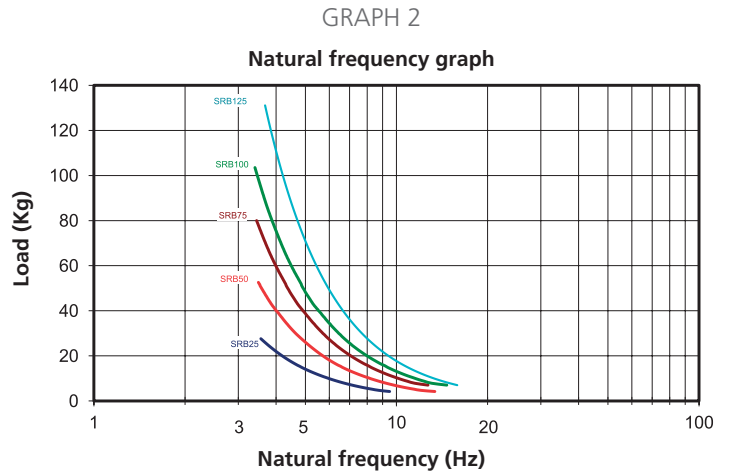
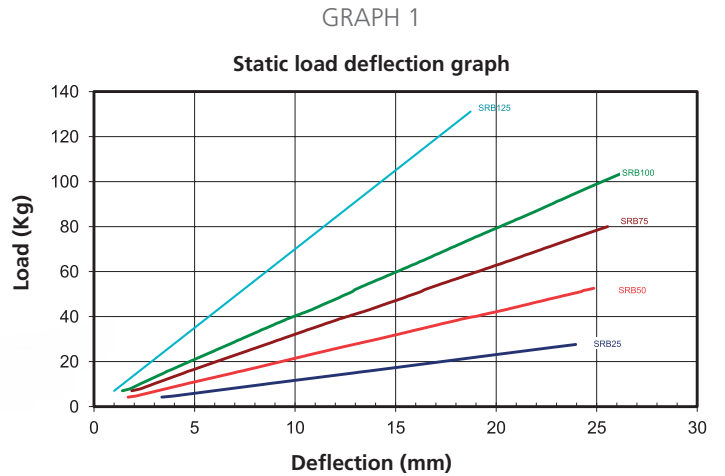
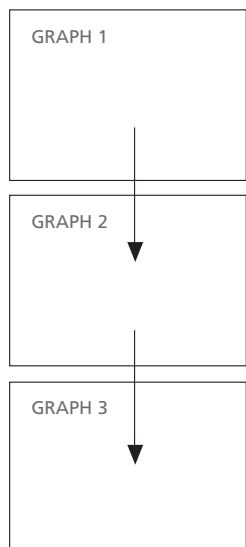

ACOUSTIC HANGERS

Spring Rubber® ceiling hanger

| | REF. AMC | MAX. PERMANENT LOAD | DIMENSIONS | | | | | CODE |
|---|----------|---------------------|------------|-----|----|----|----|-------|
| | | | A | H | B | C | E | |
|  | SRB-25 | 25 Kg | 75 | 150 | 30 | 12 | 50 | 23401 |
| | SRB-50 | 50 Kg | 75 | 150 | 30 | 12 | 50 | 23402 |
| | SRB-75 | 75 Kg | 75 | 150 | 30 | 12 | 50 | 23403 |
| | SRB-100 | 100 Kg | 75 | 150 | 30 | 12 | 50 | 23404 |
| | SRB-125 | 125 Kg | 75 | 150 | 30 | 12 | 50 | 23405 |

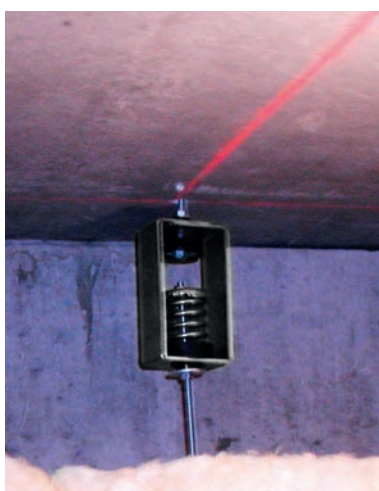

AKUSTIK+ AMC Mekanocaucho[®]

ACOUSTIC WALL TIES

EP wall mount

The EP wall mounts are manufactured in multiple formats to suit the different installation techniques. They are specially interesting for the fixation of walls exceeding 3.5m height. The EP mounts should be installed 1.5 meters in height. Example: Wall of 4.5 metres, the EP mounts should be installed at 1.5 and 3.

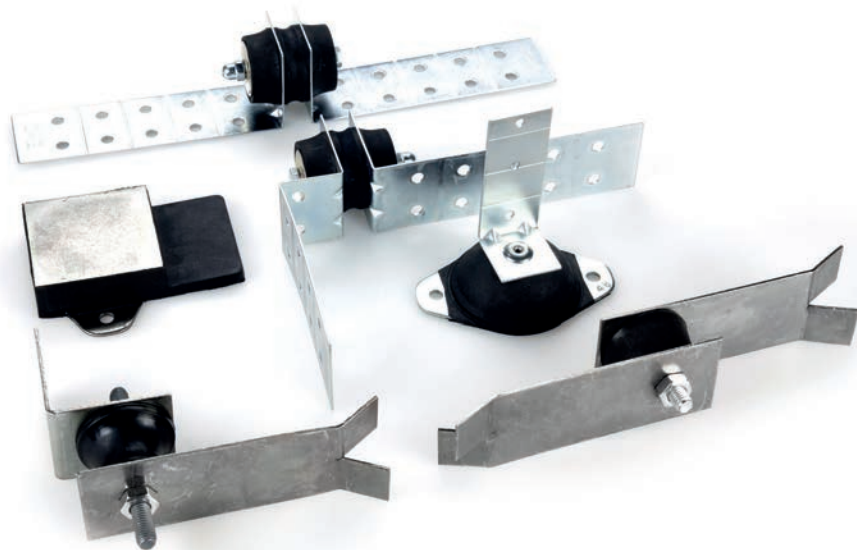

ACOUSTIC WALL TIES

EP wall mount

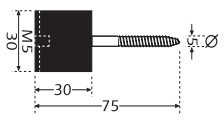
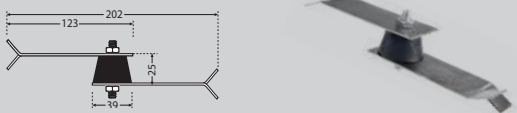
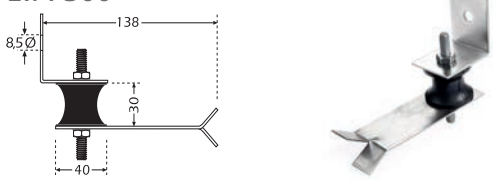
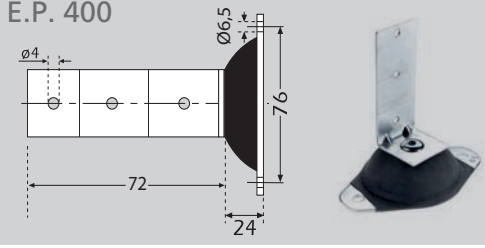
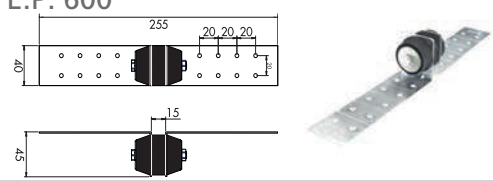
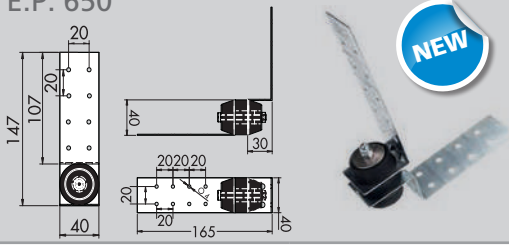
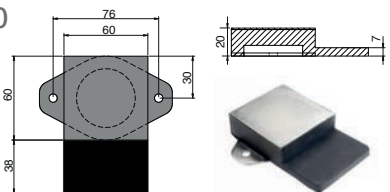
| REF. AMC | SUMMARY | LOAD MÁX. (Kg.) | CODE |
|--|---|-----------------|-------|
| E.P. 100  | Mount designed for vibration damping of walls, equipped with long ring-attached screws for threading onto wooden or plastified walls. Maximum load per acoustic element 10 kg. | | 24001 |
| E.P. 200  | Mount designed for vibration damping of walls, equipped with flanges for fitting onto concrete. Maximum load per acoustic element 10 kg. | | 24002 |
| E.P. 300  | Mount designed for vibration damping of walls, equipped with flange and angle for fitting onto concrete and threaded. Maximum load per acoustic element 10 kg. | | 24003 |
| E.P. 400  | This mount is designed to be screwed to the profile, with the possibility of choosing different distances thanks to its 3 holes. The anchoring in to the wall is made by 2 fixing flanges. | | 24004 |
| E.P. 600  | This mount is conceived to be fixed between two elements through two metal parts with "pre-drilled holes". The metal parts are easy to cut in order to adapt better to each work. | | 24008 |
| E.P. 650  | This mount is conceived to be fixed between two elements through two metal parts with "pre-drilled holes". The metal parts are easy to cut in order to adapt better to each work. Following this idea we can realise a great amount of variants in order to adapt better to each work. Please enquire us if you need a more adapted system for your work. | | 24009 |
| REF. AMC | SUMMARY | LOAD MÁX. (Kg.) | CODE |
| E.P. 500  | This mount is designed to offer an elastic base of the plasterboard plates. | 150 | 23156 |

AKUSTIK+ AMC Mekanocaucho[®]

FLOATING FLOOR MOUNTS

BF Floating floor mounts

Load from 50 to 400 kg

A range designed for use in floating floors or machinery working at more than 700 r.p.m. Manufactured in rubber SMR 5CV type with excellent mechanical insulation qualities. We are able to manufacture them in different diameters and heights.

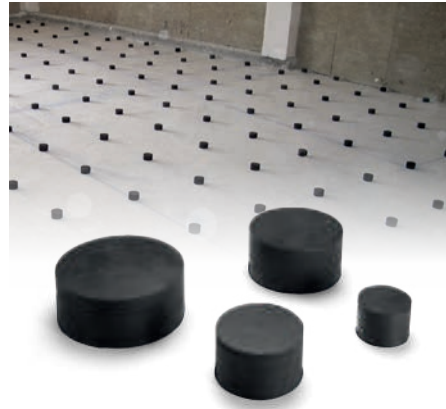

Dynamic behaviour

GRAPH 1

Static load deflection graph

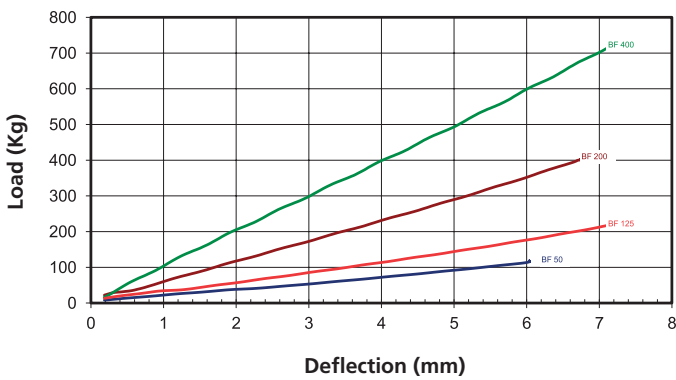

GRAPH 2

Natural frequency graph

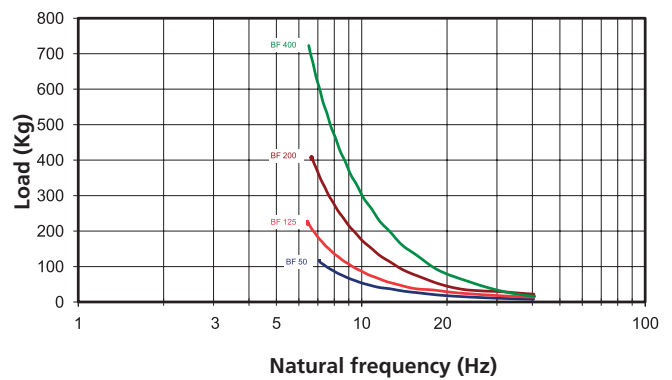

To select correct mounting, following data are needed:

- Load per mounting (kg).
- Disturbing frequency (Hz).

Select correct load line in diagram 1 and refer to diagram 2 to obtain the Natural frequency. With this natural frequency prolong this line to the diagram 3 and obtain the % of isolation at the given Excitation Frequency (Hz).

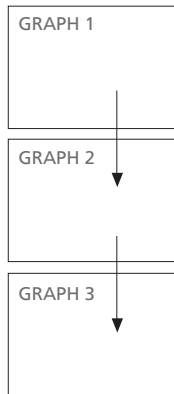

GRAPH 3

% of isolation and attenuation in dB

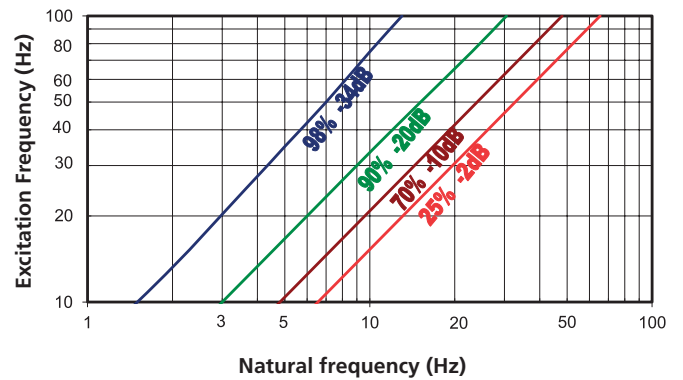

| | REF. AMC | MAX. PERMANENT LOAD | Ø | Height | CODE |
|--|----------|---------------------|----|--------|-------|
| | BF 50 | 50 Kg. | 40 | 28 | 24201 |
| | BF 125 | 125 Kg. | 60 | 36 | 24202 |
| | BF 200 | 200 Kg. | 80 | 40 | 24203 |
| | BF 400 | 400 Kg. | 95 | 40 | 24204 |

FLOATING FLOOR MOUNTS

G Floating floor mounts

Load from 300 to 800 kg

A range of rectangular mounts ideal for those instalations that do not need anchoring or fixation.



Dynamic behaviour

GRAPH 1

Static load deflection graph

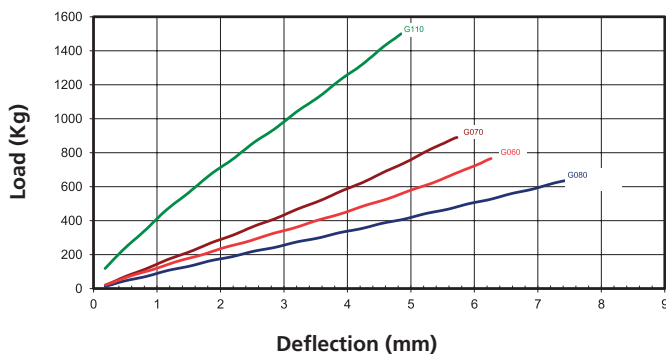

GRAPH 2

Natural frequency graph

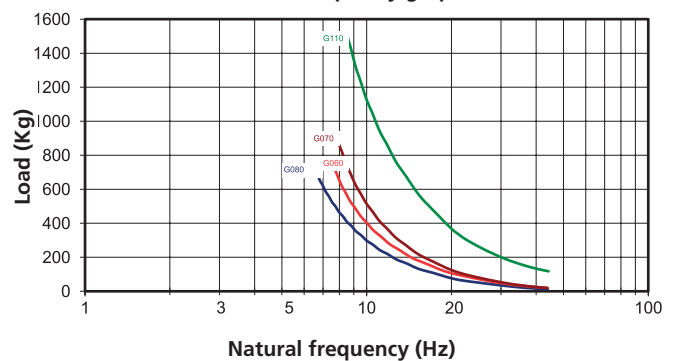

GRAPH 3

% of isolation and attenuation in dB

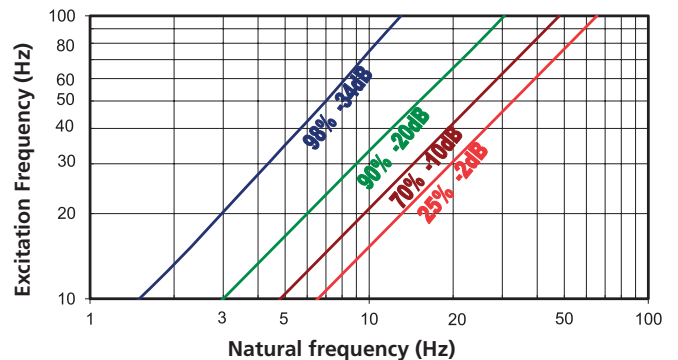

To select correct mounting, following data are needed:

- Load per mounting (kg).
- Disturbing frequency (Hz).

Select correct load line in diagram 1 and refer to diagram 2 to obtain the Natural frequency. With this natural frequency prolong this line to the diagram 3 and obtain the % of isolation at the given Excitation Frequency (Hz).

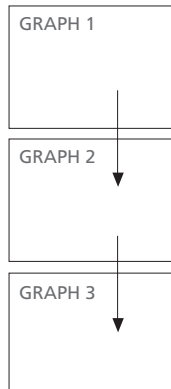

| | REF. AMC | A (mm.) | B (mm.) | LOAD MIN (Kg.) | LOAD MAX (Kg.) | CODE |
|--|----------|---------|---------|-----------------|----------------|--------|
| | G-060 | 70 | 30 | 180 | 300 | 152005 |
| | G-070 | 80 | 30 | 350 | 600 | 152006 |
| | G-090 | 100 | 40 | 200 | 500 | 152008 |
| | G-110 | 110 | 30 | 1600 | 800 | 152009 |
| | G-080 | 80 | 50 | 200 | 500 | 152007 |

AKUSTIK+ AMC Mecanocaucho[®]

TABIABSORBER

Delivery format: 1x1.25 meter layers

EFFECTIVENESS: Manufactured from CR (NEOPRENE[®]) particles and then compressed, the tabiabsorber can be furnished in two different versions depending on its use.

VERSATILITY: The TABIABSORBER can be furnished in two different versions depending on its use.

EASY TO INSTALL: Due to its exterior texture, the adherence to plaster, glue, concrete etc it is easily done thanks to its waterproofing.

TABIABSORBER 5: Shock absorber and noise isolator.

TABIABSORBER 10: Vibratory insulation.

We offer the cutting service upon requested dimensions.

| | REF. AMC | CODE |
|---|------------------------|-------|
|  | Tabiabsorber 5 | 30105 |
| | Tabiabsorber 10 | 30110 |
|  | Tabiabsorber Curl 8/4 | 30106 |
|  | Tabiabsorber Curl 17/8 | 30107 |

Dynamic behaviour

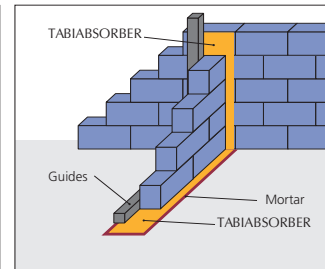
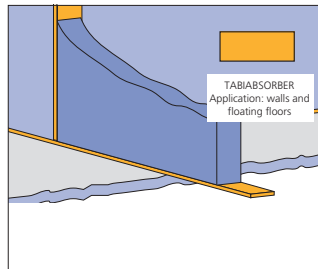
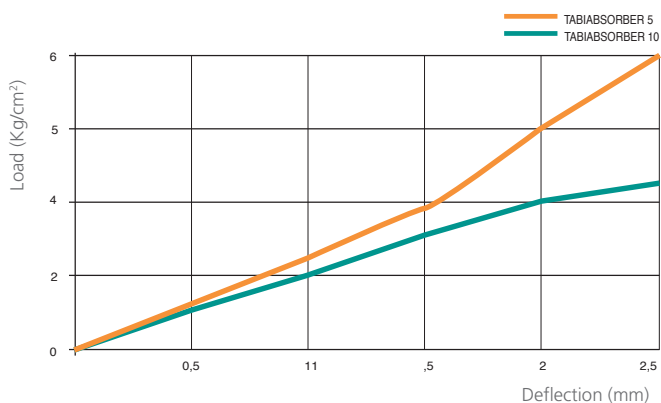

The Tabiabsorber can be cutted in bands

| | TABIABSORBER 5 CODE 30105 | TABIABSORBER 10 CODE 30110 | TABIABSORBER CURL 8/4 CODE 30106 | TABIABSORBER CURL 17/8. CODE 30107 | NORM |
|--|------------------------------|-------------------------------|--|--|-------------------|
| SIZES (m) | 1x1,25 | 1x1,25 | 8x1,25 | 8x1,25 | |
| THICKNESS (mm) | 5 mm | 10 mm | 8/4 (8 minimum + 4 on the curl zone) | 17/8 (17 minimum + 8 on the curl zone) | |
| DENSITY (Kg/m³) | 917 | 917 | 680-750 | 500-600 | |
| WEIGHT/m² (kg) | 4.1 | 8.5 | 3,87-4,73 | | |
| TENSILE STRENGTH (N/mm²) | 7 | 7,5 | 0,4 | 0,3 | DIN EN ISO 1798 |
| TEAR STRENGTH (%) | 65 | 70 | 50 | 40 | DIN EN ISO 1798 |
| STRESS AT 25% COMPRESSION (N/mm²) | 0.6 | 0.8 | 0,1 | 0,05 | DIN EN ISO 3386-2 |
| WATERPROOFING, K VALUE. (cm/s) | - | 0.03 | | | 18035/6 |
| MAX. TEMPERATURE (C°) | -40 a 115 | -40 a 115 | -30 a 80 | -30 a 80 | |
| FIRE RESISTANCE | Class B2/E | Class B2/E | Class B2/E | Class B2/E | 4102 / ISO 13501 |
| STRUCTURE NOISE IMPROVEMENT (DB) | | | 22 | 28 | |

Akustik+ by getzner **sylomer**®

When 2 dB at low frequencies
make the difference

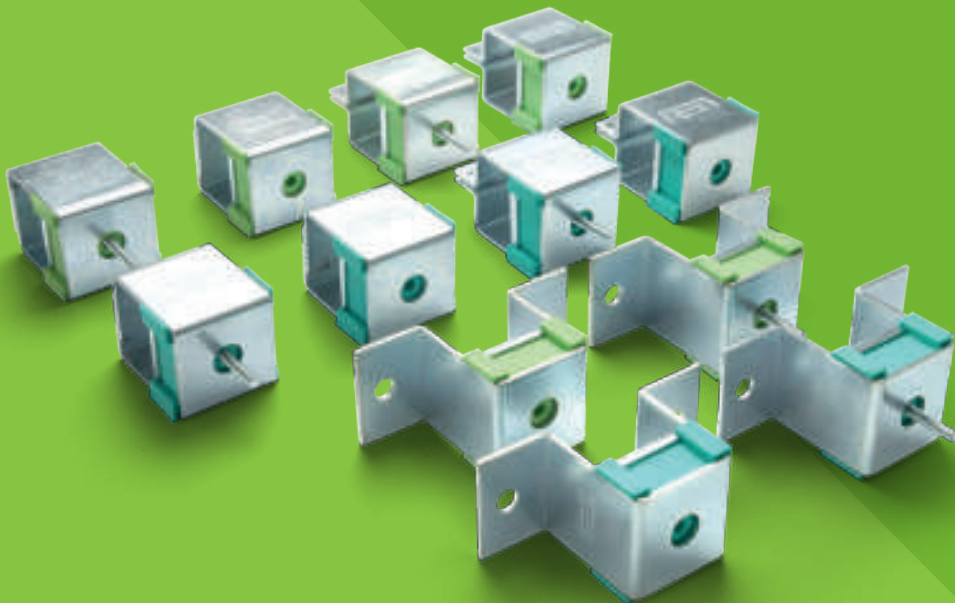

COMPARATIVE TESTS AT THE LABEIN TECHNOLOGY CENTRE

Akustik+Sylomer[®] is the trademark of a new solution for the anti-vibration mountings of false ceilings or vibrating elements that have to be suspended. They are used for the attenuation of vibrations, reducing structure-borne noise.

The **Akustik+Sylomer[®]** ceiling mounts are made of Sylomer[®], a microcelular polyurethane material specially conceived for vibration isolation. This material produces a higher degree of damping than the elastomers traditionally used for this purpose.

The **Labein** technology centre performed a series of comparative tests to confirm the good acoustic results of Akustik+Sylomer[®]. This centre is officially ENAC-certified and complies with the requirements of the ISO 140-1:1997 standard.

PURPOSE OF THE TEST

The purpose of the test is to compare, in equal conditions, the acoustic isolation to air-borne noise of a false ceiling without anti-vibration suspensions (direct transmission) to a false ceiling with the new Akustik+Sylomer[®] suspensions.

The secondary endpoint is to compare the Akustik+Sylomer[®] to another suspension with the same size-specific characteristics using high-resilience natural rubber from our Akustik 4 45 shore A standard series.

TEST METHODOLOGY

The reports contain the results of the noise isolation test to airborne noise conducted according to the UNE-EN ISO 140-3 standard for a false ceiling with the following ceiling mounts:

- Direct transmission (without antivibration suspensions).
- Akustik 4 45 shore A.
- Akustik 3 + Sylomer[®]30 Type B.

Besides the isolation curves, two RW and RA indexes have been calculated and used to compare the performance of the different suspensions. The RW noise reduction index of the sample tested and the terms of adaptation of the C and Ctr spectrum were obtained according to the ISO 717-1 standard, based on the isolation curve. The pink noise isolation index RA between 100Hz and 5 KHz is that which is specified by the Basic Spanish Building Standard: NBE-CA 88 "Acoustic Conditions".

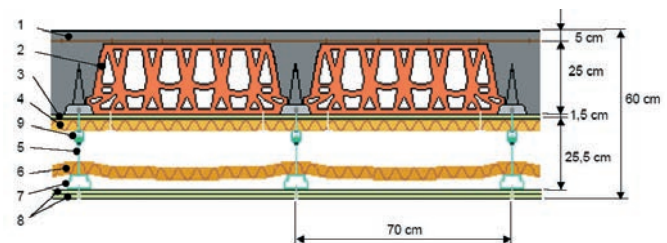
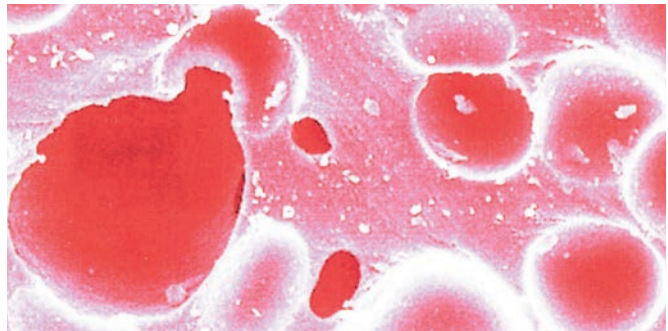

Specimen used for the test

IMPORTANT NOTE: The composition of the false ceiling is not meant to be used for teaching purposes in acoustics. It is a standard implementation whose objective is to compare the anti-vibration elements. The specimen used in the tests is a standard ceramic pot slab with an airborne isolation of $R_w(C;C_v)$: 52 (0;-3) dB.

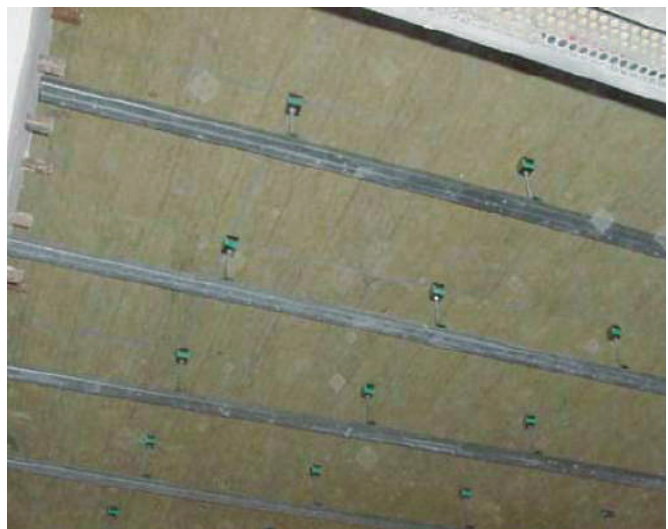

The results and the descriptive reports can be downloaded free of charge from www.akustik.com

COMPARATIVE TESTS AT THE LABEIN TECHNOLOGY CENTRE

COMPARATIVE RESULTS OF THE TEST BETWEEN A SUSPENDED CEILING WITH AND WITHOUT AKUSTIK+SYLOMER®.

Graphic 1 shows the isolation provided by a single plasterboard suspended with Akustik + Sylomer® suspensions and the same ceiling fitted with M6 rod. The blue line represents the isolation achieved with Akustik + Sylomer® mounts.

As can be seen, there are major differences at low and high frequencies, offering a difference of:

- 3 dB at 125 Hz
- 6 dB at 250 Hz
- 5 dB at 500 Hz
- 5 dB at 1000Hz

At the same time, comparative tests were conducted with ceilings with a greater number of plasterboards. Table 1 shows the results of the RW reduction index:

It is clear that the use of Akustik+Sylomer® suspensions provides far greater airborne isolations, which in some cases are equivalent to or greater than the use of 2 or 3 plasterboards with anti-vibration ceiling mounts.

The results and descriptive reports can be downloaded free from www.akustik.com

Akustik isolation curves

Graphic 1

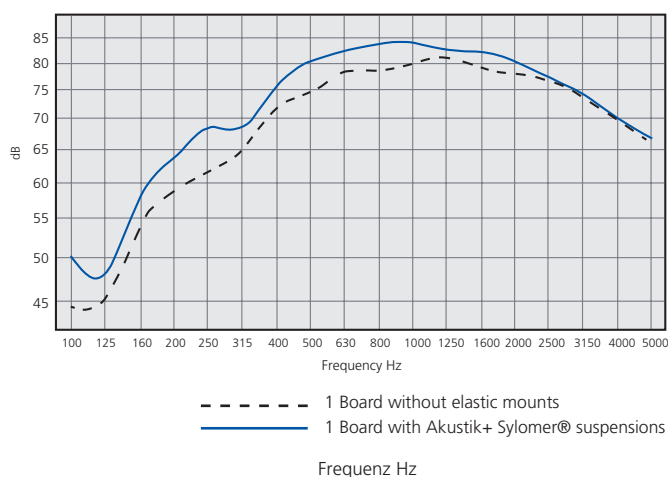
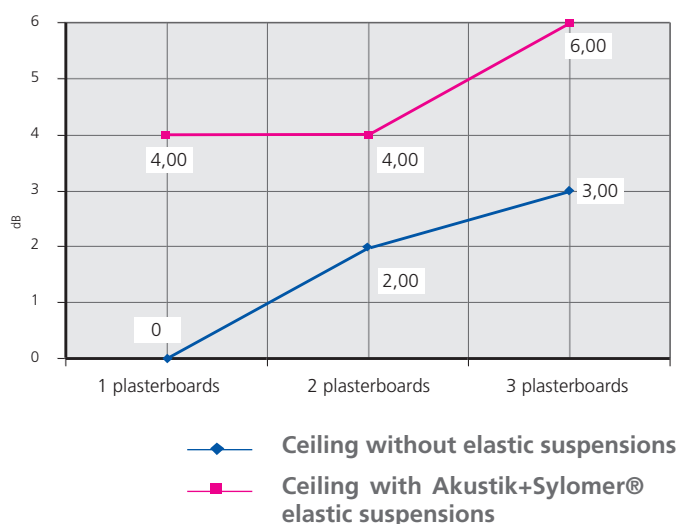

Table 1

| RW (C; Ctr) sound isolation index | Without suspensions (M6 rod) | With suspensions Akustik+sylomer®. |
|-----------------------------------|------------------------------|------------------------------------|
| 1 plasterboard | 71 (-4; -10) dB | 75 (-4; -10) dB |
| 2 plasterboard | 73 (-3; -9) dB | 75 (-3; -8) dB |
| 3 plasterboard | 74 (-3; -8) dB | 77 (-3; -8) dB |

Gain in dB thanks to the use of the Akustik+Sylomer® suspensions as opposed to a ceiling without elastic suspensions.



COMPARATIVE TESTS AT THE LABELIN TECHNOLOGY CENTRE

COMPARATIVE RESULTS OF THE TEST BETWEEN A SUSPENDED CEILING WITH AKUSTIK+SYLOMER VS RUBBER SUSPENSIONS.

Table 2 compares the RA sound isolation index according to the number of plasterboards.

The improvement is self-evident, the akustik+sylomer® mounts offer a superior isolation to the rubber mounts. This difference is so great that it may be said that a ceiling with a plasterboard with akustik+sylomer® offers the same isolation as a ceiling with two plasterboard rubber suspensions. This therefore means savings in time and material.

The savings in plasterboard and labour costs make these mounts particularly interesting, both technically and economically.

In order to provide a better analysis of the differences between the rubber mounts and the akustik+sylomer® mounts, table 3 shows the isolation data at different frequencies.

The results of these tables show that the isolation differences are in the low frequency range, which is particularly interesting for the isolation of premises without soundproofing, since they are particularly difficult to isolate.

Table 2

| RW sound isolation index | Akustik + sylomer® | RUBBER |
|--------------------------|--------------------|--------------------|
| 1 plasterboard | 75 (-4; -10) dB | 74 (-3; -9) dB |
| 2 plasterboard | 75 (-3; -8) dB | 75 dB (-4; -10) dB |
| 3 plasterboard | 77 (-3; -8) dB | 76 (-4; -10) dB |

Table 3

| Suspended ceiling with 1 plasterboard | | |
|---------------------------------------|--------------------|---------|
| FREQUENCY | Akustik + sylomer® | RUBBER |
| 160 Hz. | 58,3 dB | 57,5 dB |
| 250 Hz. | 68,4 dB | 66 dB |
| 500 Hz. | 80,3 dB | 79,1 dB |

| False ceiling with 2 plasterboards | | |
|------------------------------------|--------------------|---------|
| FREQUENCY | Akustik + sylomer® | RUBBER |
| 160 Hz. | 57 dB | 56,9 dB |
| 250 Hz. | 70 dB | 68 dB |
| 500 Hz. | 81,5 dB | 81,1 dB |

| False ceiling with 3 plasterboards | | |
|------------------------------------|--------------------|---------|
| FREQUENCY | Akustik + sylomer® | RUBBER |
| 160 Hz. | 60,4 dB | 58,5 dB |
| 250 Hz. | 69,4 dB | 67 dB |
| 500 Hz. | 82,4 dB | 81,1 dB |

ADVANTAGES ON WOODEN STRUCTURES

In order to show the acoustic advantages when using Akustik+Sylomer® acoustic hangers, the German IFT Rosenheim technological center has performed Impact and airborne noise tests using 2 different types of wooden structures.

IFT ROSENHEIM

Wooden ceiling using sand as a filler: Reduction of impact noise 19dB, Gain of airborne isolation 18 dB.

Wooden ceiling using mineral wool as a filler: Reduction of impact noise 14 dB, Gain of airborne isolation 6 dB.

In both kinds of ceilings a comparison has been done in order to determine the acoustic advantage that provides using Akustik+Sylomer® hangers.



Akustik Lateral+Sylomer®: The akustik Lateral hanger is specifically suiting the structures where no space is available and the acoustic hangers have to be fixed to the wooden beam.

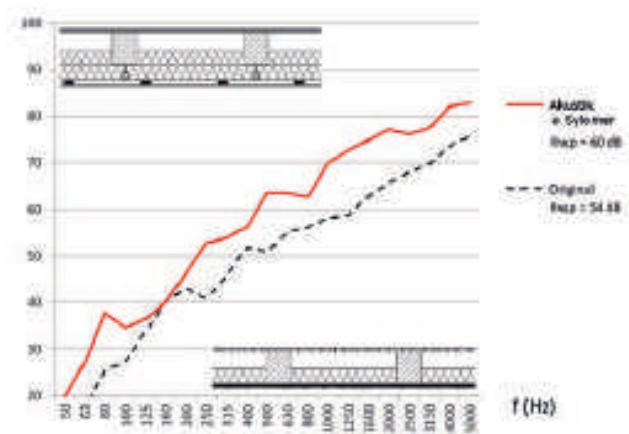
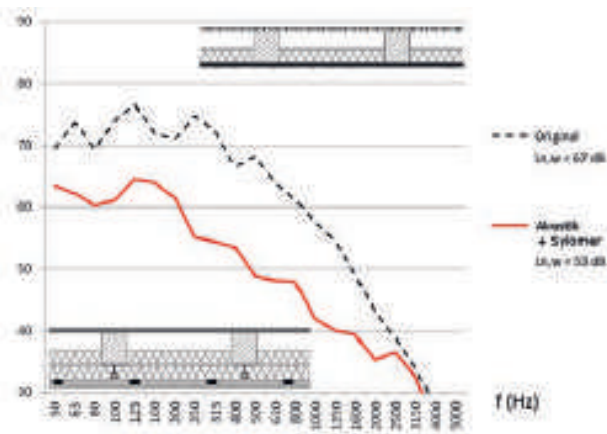
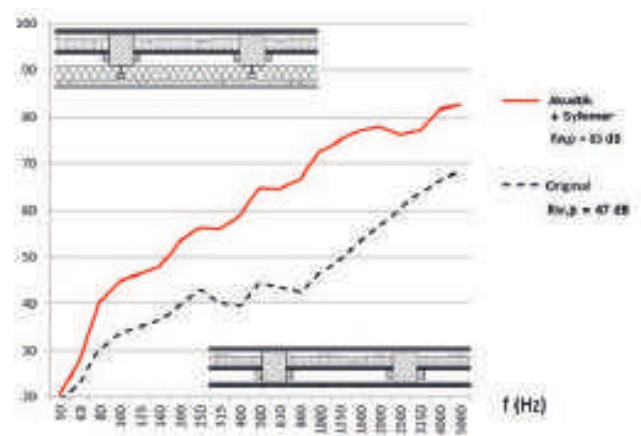
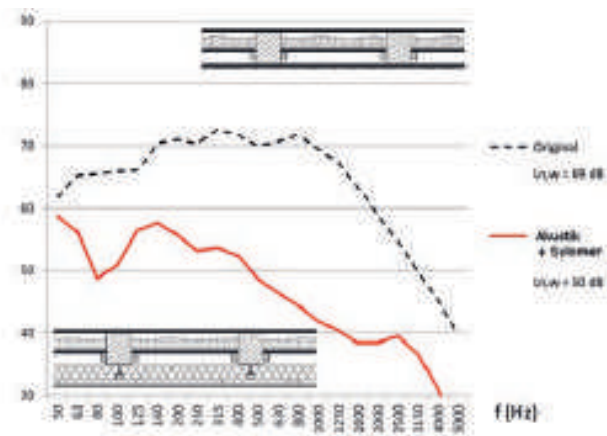

AKUSTIK + sylomer[®] by getzner

BEHAVIOUR AT HIGH AND LOW FREQUENCIES

Structure-borne noise is transmitted through the structures of a building, machine, installation... This radiation noise becomes airborne noise.

Low noise frequencies are those that are usually less damped in the air and are therefore better transmitted through structures. The range of low frequencies is between 20 and 500 Hz.

NATURAL FREQUENCY OF THE AKUSTIK+SYLOMER[®] MOUNTS

The Akustik+Sylomer[®] ceiling mounts can obtain very low natural frequencies of up to 7 Hz at the optimal loading point. At this loading point the decoupling frequency of the Akustik+Sylomer[®] mounts is 9,9Hz.

Such a low natural frequency is optimal for the false ceilings of soundproofed premises. This type of suspensions are also particularly interesting for the isolation of machines or

vibrating elements that work at more than 600 rpm. Examples are:

- Ducts / pipelines:
 - Of cooling liquids from refrigerating compressors, and are ideal for use in supermarkets, the frozen food section.
 - Air conditioning.
 - Pumping of water
 - From fume exhausts.
- Suspension of air conditioning machinery.
- Suspension of vibrating elements in general.

BEHAVIOUR OF THE AKUSTIK+SYLOMER[®] MOUNTS AT LOW FREQUENCIES IN SOUNDPROOFED PREMISES.

The range of audible frequencies in the human being may vary according to age and to other factors although in general it is between 20 Hz and 20.000Hz. By way of example the notes produced by a guitar have a frequency range from 82

to 698 Hz.

Considering that the most unfavourable excitation frequency, i.e. 20 Hz, the isolation degree of structure-borne noise produced by an Akustik+Sylomer[®] suspension would be close to 90%. (*)

(*) Installation of the optimal loading point of the Akustik+Sylomer[®] for a theoretical single mass spring system.

BEHAVIOUR OF THE AKUSTIK+SYLOMER[®] MOUNTS AT MEDIUM AND HIGH FREQUENCIES.

Sound waves are not comprised of just one frequency, but rather of a set of frequencies superimposed without any order, which is the main reason why noise is unpleasant. Thus, the ideal suspender must be able to isolate the broadest possible range of frequencies.

Behaviour of a metal spring

These suspenders are often recommended for the elastic

suspension of false ceilings. It is important to know that this type of mount is suitable for the damping of low frequencies, whereas the high frequencies are propagated through the coils of the spring. To filter this type of frequencies the springs must be combined with a stage of viscoelastic material under the spring to stop the propagation of this type of vibration.

BEHAVIOUR OF THE AKUSTIK+ SYLOMER[®]

Thanks to the viscoelastic properties of the Sylomer, the akustik+Sylomer has a behaviour similar to the spring at low frequencies and at the same time not only prevents the high frequencies as occurs in the spring via its coils, but also considerably improves the behaviour of the rubber at high frequencies. These results are shown in the comparative section of Akustik+Sylomer[®] with regard to rubber suspenders.

CREEPING AND LONG-TERM BEHAVIOUR

Static loads produce a certain degree of creeping. This phenomenon can be observed in all elastomers. Creeping is the increase in deformation under consistent loading Figs. 1 and 3 show the creeping for the two types of Sylomer[®] used for our ceiling mounts.

Within the field recommended for the application of continuous loads, the additional deflection remains under 50% of the initial deflection even after an extended period of 10 years.

The dynamic stiffness of the ceiling mounts must increase as little as possible over time. Figs. 2 and 4 show the variation of the dynamic module over time of the two types of Sylomer used in our ceiling mounts.

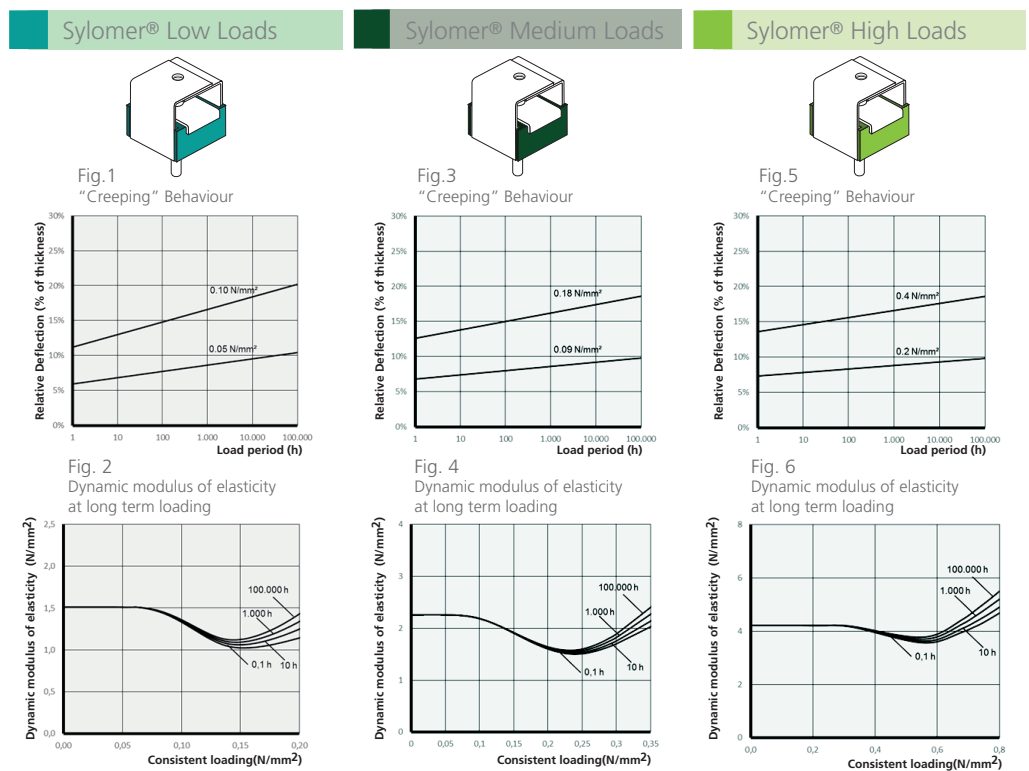

ACOUSTIC HANGERS

Akustik+Sylomer®: Models and dimensions



PRODUCT DESCRIPTION

These antivibration mounts have been conceived for the suspension of false ceilings, vibrating pipelines and machinery that has to be suspended.

The excellent properties of the Sylomer® micro-cellular polyurethane material achieve elevated isolation values as opposed to other mounts that use rubber or cork, or a combination of both. These antivibration mounts are manu-

factured in two special mixes of Sylomer® to adapt better to the load of each application.

A great variety of fixing metal armor and elements facilitate the installation and to adapt better to each type of job. Their rugged metal parts can withstand tensile stresses from 650Kg to 1000Kg. They are supplied with an anticorrosive treatment that can withstand the toughest environments.

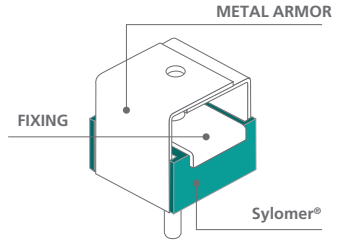

| | | | | |
|--|---------------------------------|--|--|--|
| | <p>Akustik 1</p> | <p>It is secured directly to the ceiling by means of two holes.</p> | | |
| | <p>Akustik 3</p> | <p>It is secured directly to the ceiling with a screw and locking nut.</p> | | |
| | <p>Akustik 4</p> | <p>It is secured with a screw via a nut welded to the metal armor.</p> | | |
| | <p>Akustik 4 High</p> | <p>It is secured with a screw via a nut welded to the metal armor.</p> | | |
| | <p>Akustik Rapid T47</p> | <p>Designed to be secured to most profiles on the market. Its design makes for easy and safe installations.</p> | | |
| | <p>Akustik Safety</p> | <p>Its gravitational system guarantees correct installation and offers greater safety, preventing elements from becoming detached.</p> | | |

AKUSTIK + sylomer[®] by getzner

CEILING MOUNTS Akustik+Sylomer[®]: Models and dimensions



TYPE OF FIXING

TYPE A

For installations where M6 male fixing is required, the recommended fixing is **Type A**.

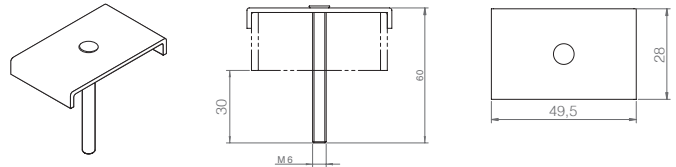

TYPE B

For installations where M6 female fixing is required, the recommended fixing is **Type B**.

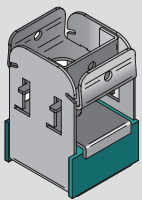
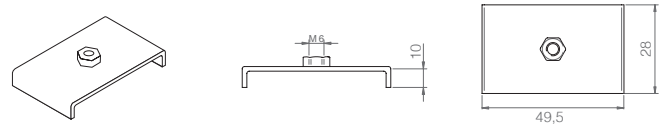

Akustik Super T47

The "SUPER" security feature is adaptable to the different profiles existing on the market.

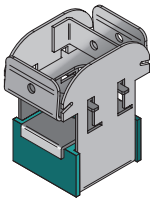
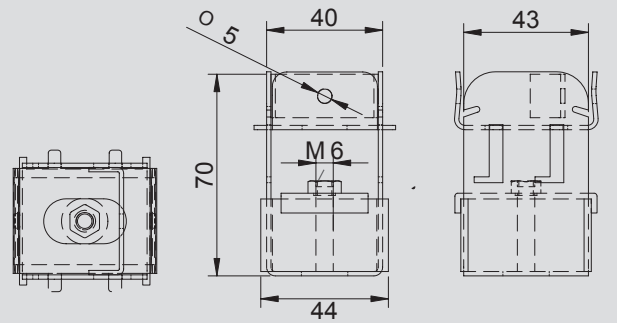

Akustik Super T60

The external dimension of the profiles that exist on the market may vary, our "SUPER" security system with lip adapts to the different lengths of the profile having a tight fit.

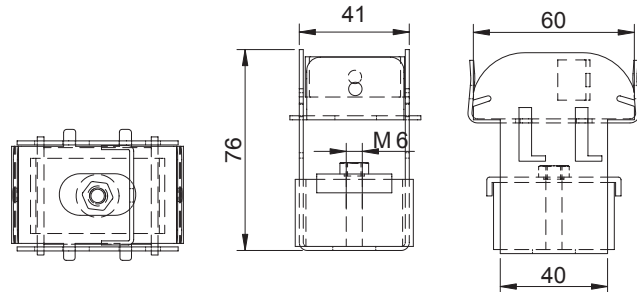

INSTALLATION STEPS OF AKUSTIK SUPER

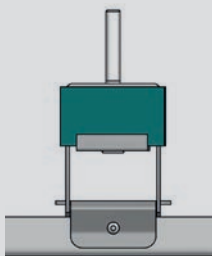

Detail A

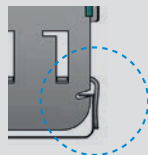

1• The security system is adaptable to different widths of profiles.

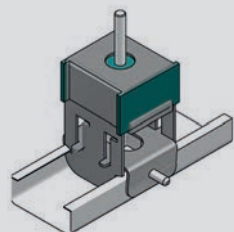

Detail B

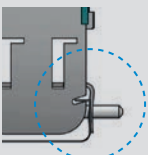

2• The "SUPER" security system admits the possibility of inserting a blocking screw.

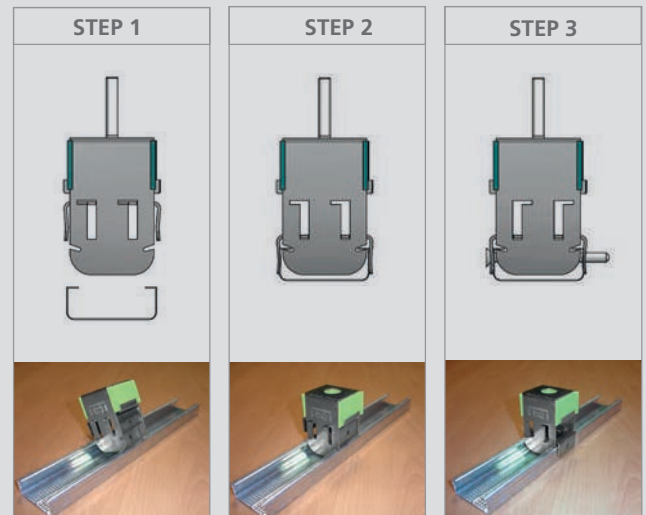

ACOUSTIC HANGERS

Akustik+Sylomer®: Models and dimensions

TYPES OF SYLOMER®

LOAD DEFLECTION GRAPH
Akustik+Sylomer® 30 ■

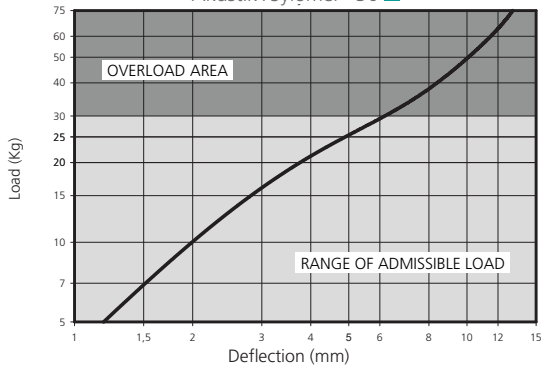

NATURAL FREQUENCY GRAPHS
Akustik+Sylomer® 30 ■

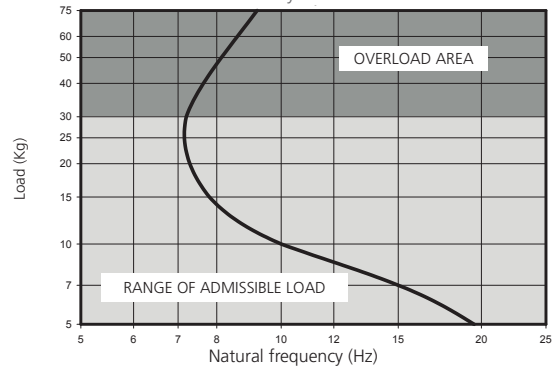

LOAD DEFLECTION GRAPH
Akustik+Sylomer® 50 ■

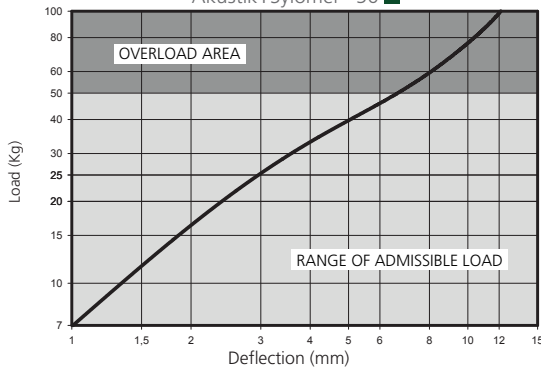

NATURAL FREQUENCY GRAPHS
Akustik+Sylomer® 50 ■

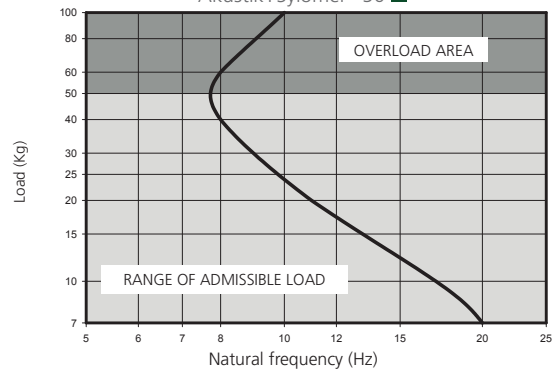

LOAD DEFLECTION GRAPH
Akustik+Sylomer® 75 ■

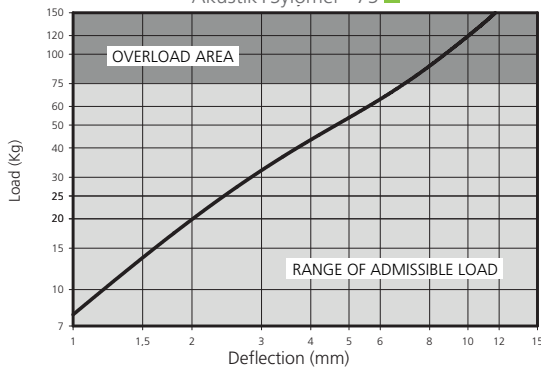

NATURAL FREQUENCY GRAPHS
Akustik+Sylomer® 75 ■

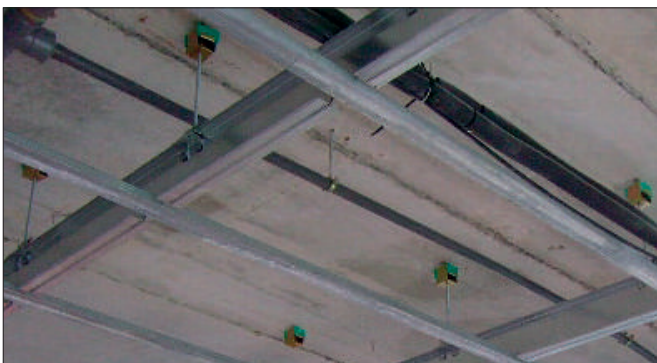
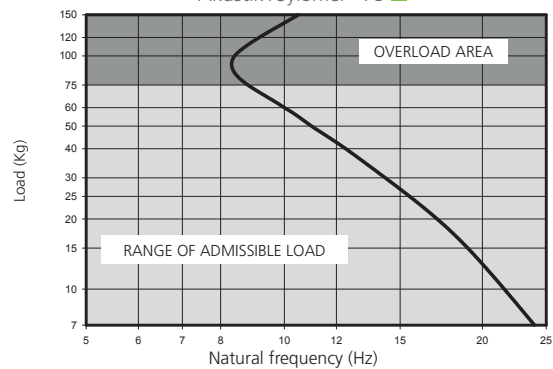

Application of an Akustik 4+Sylomer 30 type A.



Application of an Akustik Super T60 +Sylomer 30 type B.

AKUSTIK + sylomer[®]

ACOUSTIC HANGERS Akustik+Sylomer[®] Range

| REF AMC | SUMMARY | MAX. LOAD (Kg) | CODE |
|---|---|----------------|-------|
|  Akustik 1+Sylomer [®] 30 Type A | Metal armor of the Akustik 1 secured to the ceiling by an M6 screw and with a nut. | 30 | 23501 |
|  Akustik 3+Sylomer [®] 30 Type A | Metal armor of the Akustik 3 secured to the ceiling by an M6 screw and with a nut. | 30 | 23503 |
|  Akustik 4+Sylomer [®] 30 Type A | Metal armor of the Akustik 4 secured to the ceiling by an M6 screw and with a nut. | 30 | 23505 |
|  Akustik 4 High+Sylomer [®] 30 Type A | Metal armor of the Akustik 4 secured to the ceiling by an M6 screw and with a nut. | 30 | 23537 |
|  Akustik Rapid+Sylomer [®] 30 Type A | Metal armor of the Akustik rapid secured to the ceiling by an M6 screw and with a nut. | 30 | 23507 |
|  Akustik Safety+Sylomer [®] 30 Type A | Metal armor of the Akustik Safety secured to the ceiling by an M6 screw and with a nut. | 30 | 23508 |
|  Akustik 1+Sylomer [®] 30 Type B | Metal armor of the Akustik 3 secured to the ceiling by a welded M6 nut. | 30 | 23509 |
|  Akustik 3+Sylomer [®] 30 Type B | Metal armor of the Akustik 4 secured to the ceiling by a welded M6 nut. | 30 | 23511 |
|  Akustik 4+Sylomer [®] 30 Type B | Metal armor of the Akustik Rapid secured to the ceiling by a welded M6 nut. | 30 | 23513 |
|  Akustik 4 High+Sylomer [®] 30 Type B | Metal armor of the Akustik Rapid secured to the ceiling by a welded M6 nut. | 30 | 23538 |
|  Akustik Rapid+Sylomer [®] 30 Type B | Metal armor of the Akustik Safety secured to the ceiling by an M6 screw. | 30 | 23515 |
|  Akustik Safety+Sylomer [®] 30 Type B | Metal armor of the Akustik Safety secured to the ceiling by a welded M6 nut. | 30 | 23516 |

ACOUSTIC HANGERS

Akustik+Sylomer® Range

| REF AMC | SUMMARY | MAX. LOAD (Kg) | CODE |
|--|--|----------------|--------------|
|  <p>Akustik 1+Sylomer® 50 Type A</p> | Metal armor of the Akustik 1 secured to the ceiling by an M6 screw and with a nut. | 50 | 23502 |
|  <p>Akustik 3+Sylomer® 50 Type A</p> | Metal armor of the Akustik 3 secured to the ceiling by an M6 screw and with a nut. | 50 | 23569 |
|  <p>Akustik 4+Sylomer® 50 Type A</p> | Metal armor of the Akustik 4 secured to the ceiling by an M6 screw and with a nut. | 50 | 23578 |
|  <p>Akustik 4 High+Sylomer® 50 Type A</p> | Metal armor of the Akustik 4 secured to the ceiling by an M6 screw and with a nut. | 50 | 23580 |
|  <p>Akustik Rapid+Sylomer® 50 Type A</p> | Metal armor of the Akustik rapid secured to the ceiling by an M6 screw and with a nut. | 50 | 23582 |
|  <p>Akustik 1+Sylomer® 50 Type B</p> | Metal armor of the Akustik 3 secured to the ceiling by a welded M6 nut. | 50 | 23520 |
|  <p>Akustik 3+Sylomer® 50 Type B</p> | Metal armor of the Akustik 4 secured to the ceiling by a welded M6 nut. | 50 | 23570 |
|  <p>Akustik 4+Sylomer® 50 Type B</p> | Metal armor of the Akustik Rapid secured to the ceiling by a welded M6 nut. | 50 | 23581 |
|  <p>Akustik 4 High+Sylomer® 50 Type B</p> | Metal armor of the Akustik Rapid secured to the ceiling by a welded M6 nut. | 50 | 23539 |
|  <p>Akustik Rapid+Sylomer® 50 Type B</p> | Metal armor of the Akustik Safety secured to the ceiling by an M6 screw. | 50 | 23583 |

AKUSTIK + sylomer[®]

ACOUSTIC HANGERS Akustik+Sylomer[®] Range

| REF. AMC | SUMMARY | MAX. LOAD (Kg) | CODE |
|---|--|----------------|-------|
|  Akustik 1+Sylomer [®] 75 Type A | Metal armor of the Akustik 1 secured to the ceiling by an M6 screw and with a nut. | 75 | 23517 |
|  Akustik 3+Sylomer [®] 75 Type A | Metal armor of the Akustik 3 secured to the ceiling by an M6 screw and with a nut. | 75 | 23519 |
|  Akustik 4+Sylomer [®] 75 Type A | Metal armor of the Akustik 4 secured to the ceiling by an M6 screw and with a nut. | 75 | 23521 |
|  Akustik 4 High+Sylomer [®] 75 Type A | Metal armor of the Akustik 4 secured to the ceiling by an M6 screw and with a nut. | 75 | 23540 |
|  Akustik Rapid+Sylomer [®] 75 Type A | Metal armor of the Akustik rapid secured to the ceiling by an M6 screw and with a nut. | 75 | 23523 |
|  Akustik 1+Sylomer [®] 75 Type B | Metal armor of the Akustik 3 secured to the ceiling by a welded M6 nut. | 75 | 23525 |
|  Akustik 3+Sylomer [®] 75 Type B | Metal armor of the Akustik 4 secured to the ceiling by a welded M6 nut. | 75 | 23527 |
|  Akustik 4+Sylomer [®] 75 Type B | Metal armor of the Akustik Rapid secured to the ceiling by a welded M6 nut. | 75 | 23529 |
|  Akustik 4 High+Sylomer [®] 75 Type B | Metal armor of the Akustik Rapid secured to the ceiling by a welded M6 nut. | 75 | 23539 |
|  Akustik Rapid+Sylomer [®] 75 Type B | Metal armor of the Akustik Safety secured to the ceiling by an M6 screw. | 75 | 23531 |

ACOUSTIC HANGERS



Akustik Super+Sylomer® Range

| REF. AMC | SUMMARY | MAX. LOAD (KG) | CODE |
|---|---|----------------|-------|
|  Akustik Super T60 +Sylomer® 30 Type A | Metal armor of the Akustik Super secured to the ceiling by an M6 screw. | 30 | 23831 |
|  Akustik Super T60 +Sylomer® 30 Type B | Metal armor of the Akustik Super secured to the ceiling by an M6 screw. | 30 | 23832 |
|  Akustik Super T47 +Sylomer® 30 Type A | Metal armor of the Akustik Super secured to the ceiling by an M6 screw. | 30 | 23821 |
|  Akustik Super T47 +Sylomer® 30 Type B | Metal armor of the Akustik Super secured to the ceiling by an M6 screw. | 30 | 23822 |
|  Akustik Super T60 +Sylomer® 50 Type A | Metal armor of the Akustik Super secured to the ceiling by an M6 screw. | 50 | 23590 |
|  Akustik Super T60 +Sylomer® 50 Type B | Metal armor of the Akustik Super secured to the ceiling by an M6 screw. | 50 | 23591 |
|  Akustik Super T47 +Sylomer® 50 Type A | Metal armor of the Akustik Super secured to the ceiling by an M6 screw. | 50 | 23588 |
|  Akustik Super T47 +Sylomer® 50 Type B | Metal armor of the Akustik Super secured to the ceiling by an M6 screw. | 50 | 23589 |
|  Akustik Super T60 +Sylomer® 75 Type A | Metal armor of the Akustik Super secured to the ceiling by an M6 screw. | 75 | 23851 |
|  Akustik Super T60 +Sylomer® 75 Type B | Metal armor of the Akustik Super secured to the ceiling by an M6 screw. | 75 | 23852 |
|  Akustik Super T47 +Sylomer® 75 Type A | Metal armor of the Akustik Super secured to the ceiling by an M6 screw. | 75 | 23841 |
|  Akustik Super T47 +Sylomer® 75 Type B | Metal armor of the Akustik Super secured to the ceiling by an M6 screw. | 75 | 23842 |

AKUSTIK + **sylomer**[®] by getzner

ACOUSTIC HANGERS

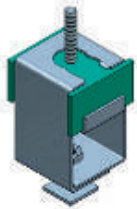
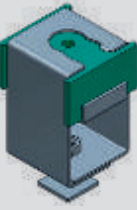
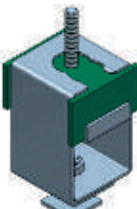
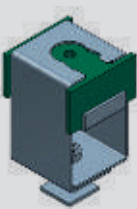
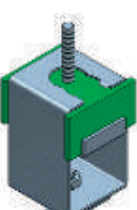
Akustik Saw+Sylomer[®] Range

| REF. AMC | SUMMARY | MAX. LOAD (KG) | CODE |
|---|---|----------------|-------|
|  <p>Akustik Saw +Sylomer[®] 30 Type A</p> <p>NEW</p> | Fitted directly to ceiling using two holes. | 30 | 23863 |
|  <p>Akustik Saw +Sylomer[®] 30 Type B</p> <p>NEW</p> | Fitted directly to ceiling using two holes. | 30 | 23864 |
|  <p>Akustik Saw +Sylomer[®] 50 Type A</p> <p>NEW</p> | Fitted directly to ceiling using two holes. | 50 | 23584 |
|  <p>Akustik Saw +Sylomer[®] 50 Type B</p> <p>NEW</p> | Fitted directly to ceiling using two holes. | 50 | 23585 |
|  <p>Akustik Saw +Sylomer[®] 75 Type A</p> <p>NEW</p> | Fitted directly to ceiling using two holes. | 75 | 23865 |
|  <p>Akustik Saw +Sylomer[®] 75 Type B</p> <p>NEW</p> | Fitted directly to ceiling using two holes. | 75 | 23866 |

ACOUSTIC HANGERS

Akustik GB + Sylomer®

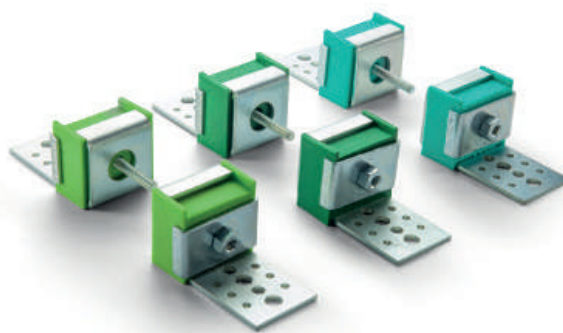



PRODUCT DESCRIPTION

These simple but effective acoustic hangers are designed for the installation of suspended ceilings, pipelines and machinery.

The Sylomer® microcellular polyurethane material provides superior isolation than rubber and/or cork materials and two versions are available depending on the load capacity required.

Type A is supplied with a rod to fix to a channel/bracket and Type B has an integrated nut for quick fixing of a suspension rod.

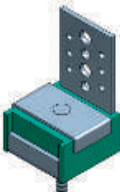
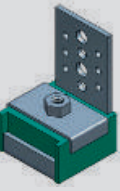
All metal parts have anti-corrosion zinc-plating.

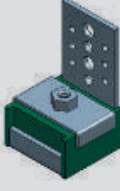
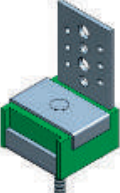
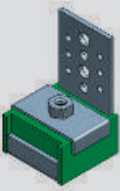
| REF. AMC | SUMMARY | MAX. LOAD (KG) | CODE |
|---|---|----------------|-------|
|  Akustik GB + Sylomer® 30 Type A | It is secured directly to the ceiling with two holes and to the profile by means of a "type A" male screw. | 30 | 23105 |
|  Akustik GB + Sylomer® 30 Type B | It is secured directly to the ceiling by means of two screws and to the profile by means of a "type B" female fixing. | 30 | 23106 |
|  Akustik GB + Sylomer® 50 Type A | It is secured directly to the ceiling with two holes and to the profile by means of a "type A" male screw. | 50 | 23592 |
|  Akustik GB + Sylomer® 50 Type B | It is secured directly to the ceiling by means of two screws and to the profile by means of a "type B" female fixing. | 50 | 23593 |
|  Akustik GB + Sylomer® 75 Type A | It is secured directly to the ceiling with two holes and to the profile by means of a "type A" male screw. | 75 | 23107 |
|  Akustik GB + Sylomer® 75 Type B | It is secured directly to the ceiling by means of two screws and to the profile by means of a "type B" female fixing. | 75 | 23108 |

AKUSTIK + sylomer[®] by getzner

ACOUSTIC HANGERS Akustik Lateral+Sylomer[®]

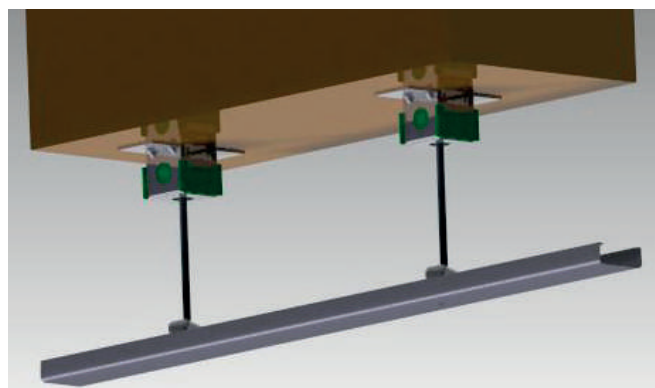
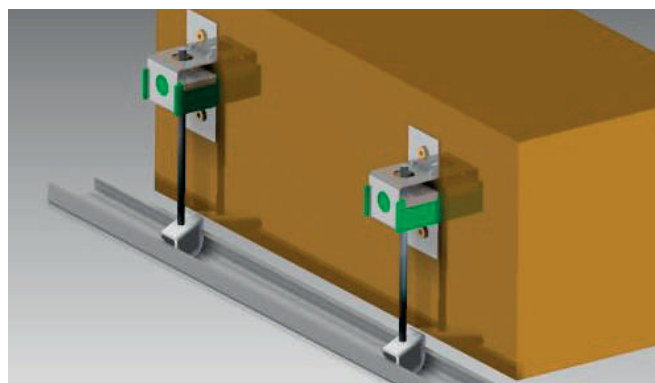
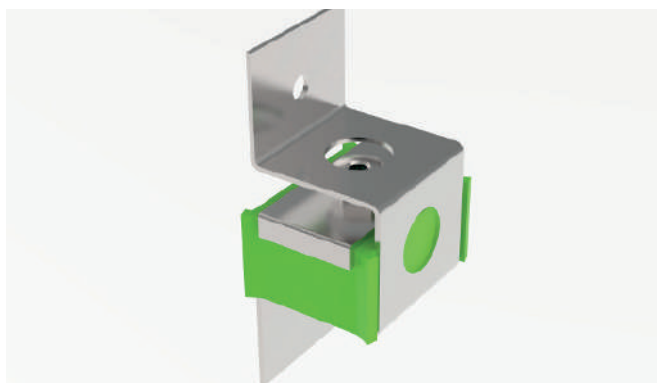
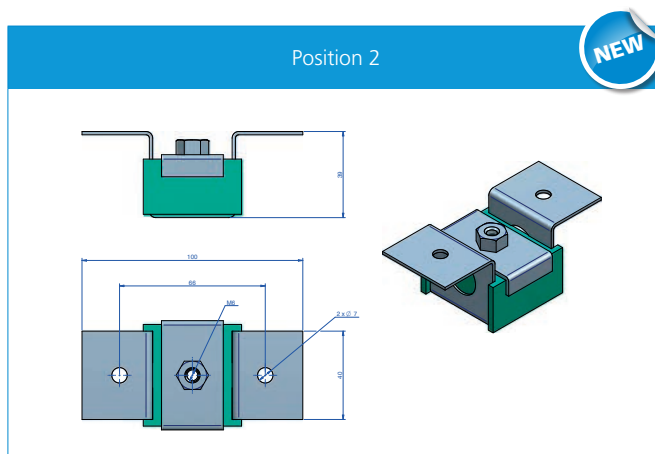
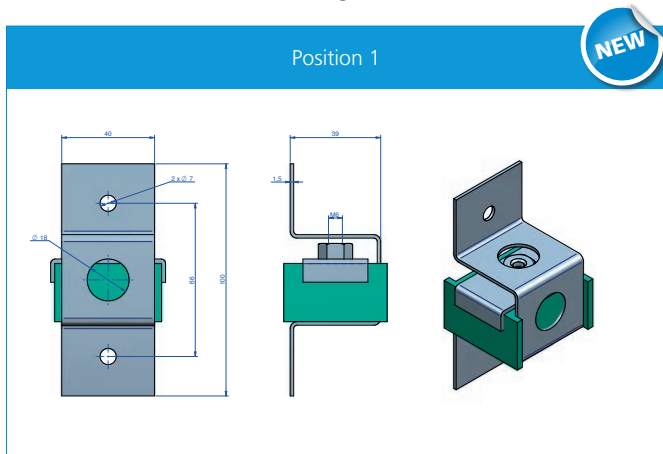

| REF. AMC | MAX. LOAD (Kg) | CODE |
|--|----------------|-------|
| Akustik 1 Lateral+Sylomer [®] 30 Type A | 30 | 23573 |
| Akustik 1 Lateral+Sylomer [®] 50 Type A | 50 | 23586 |
| Akustik 1 Lateral+Sylomer [®] 75 Type A | 75 | 23574 |
| Akustik 1 Lateral+Sylomer [®] 30 Type B | 30 | 23510 |
| Akustik 1 Lateral+Sylomer [®] 50 Type A | 50 | 23587 |
| Akustik 1 Lateral+Sylomer [®] 75 Type B | 75 | 23526 |

ACOUSTIC HANGERS

Grand Akustik+Sylomer®:

Models and dimensions



PRODUCT DESCRIPTION

These antivibration mounts have been conceived for the suspension of false ceilings, vibrating pipelines and machinery that has to be suspended.

The excellent properties of the Sylomer® micro-cellular polyurethane material achieve elevated isolation values as opposed to other mounts that use rubber or cork, or a combination of both. These antivibration mounts are manu-

factured in two special mixes of Sylomer® to adapt better to the load of each application.

A great variety of fixing metal armors and elements facilitate the installation and to adapt better to each type of job. Their rugged metal parts can withstand tensile stresses from 650Kg to 1000Kg. They are supplied with an anticorrosive treatment that can withstand the toughest environments.

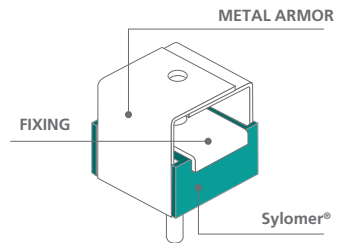

| | | |
|--|---|--|
| | <p>Grand Akustik 1</p> <p>It is secured to the ceiling with two holes.</p> | |
| | <p>Grand Akustik 2</p> <p>It is secured directly to the ceiling by means of a screw.</p> | |
| | <p>Grand Akustik 3</p> <p>It is secured directly to the ceiling by means of one screw and to the "inverted double T" type profile thanks to the design of its metal armor.</p> | |

AKUSTIK + sylomer[®] by getzner

ACOUSTIC HANGERS Grand Akustik+Sylomer[®]: Models and dimensions

TYPE OF FIXING

Type A

For installations where M6 male fixing is required, the recommended fixing is **Type A**.

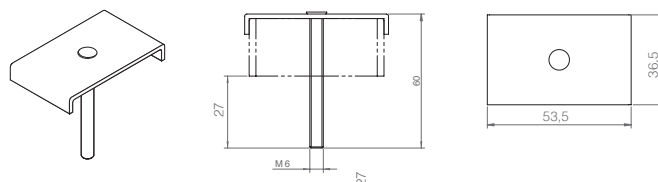

Type B

For installations where M6 female fixing is required, the recommended fixing is **Type B**.

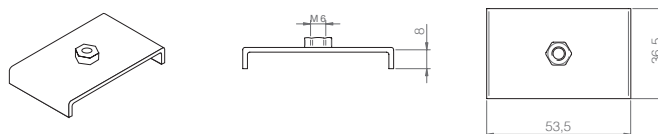

TYPES OF SYLOMER

LOAD DEFLECTION GRAPH
Grand Akustik+Sylomer[®] 60

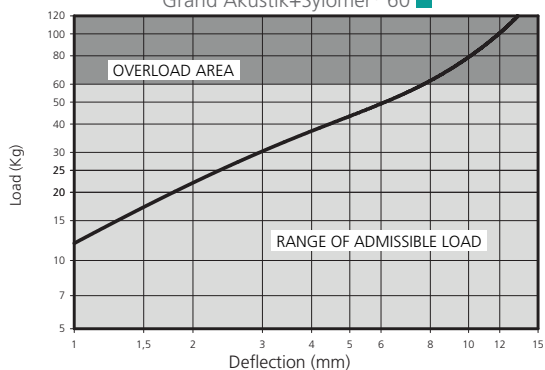

NATURAL FREQUENCY GRAPHS
Grand Akustik+Sylomer[®] 60

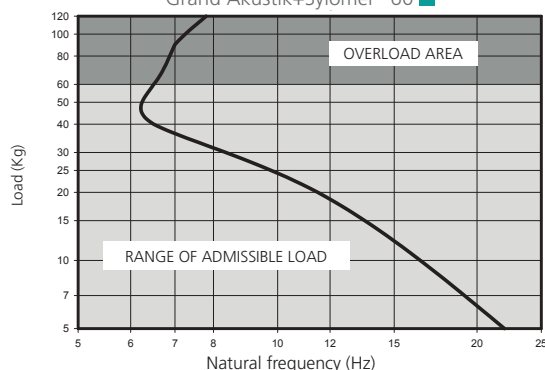

LOAD DEFLECTION GRAPH
Grand Akustik+Sylomer[®] 100

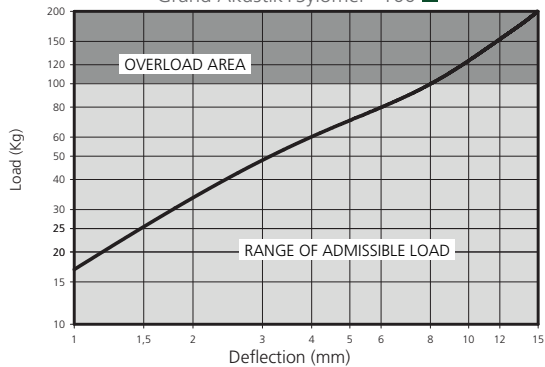

NATURAL FREQUENCY GRAPHS
Grand Akustik+Sylomer[®] 100

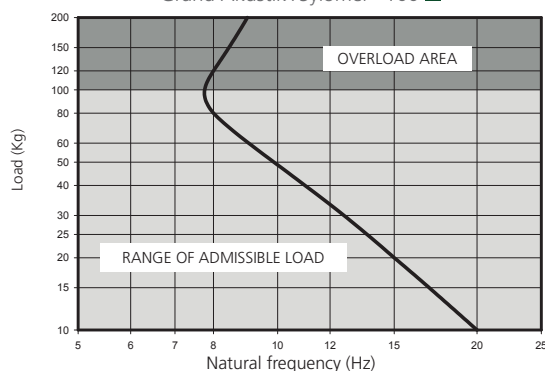

LOAD DEFLECTION GRAPH
Grand Akustik+Sylomer[®] 150

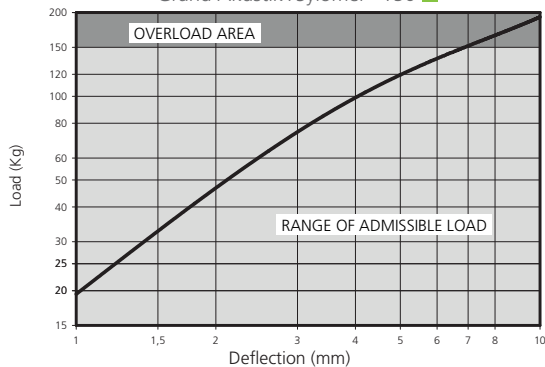

NATURAL FREQUENCY GRAPHS
Grand Akustik+Sylomer[®] 150

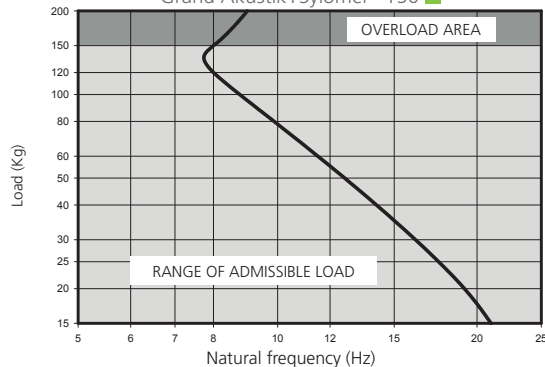

ACOUSTIC HANGERS

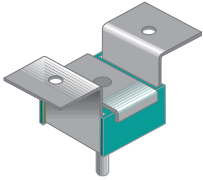
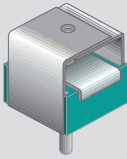
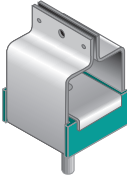
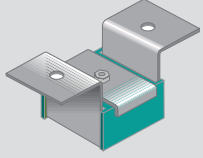
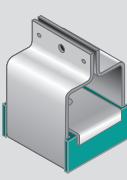

Grand Akustik+Sylomer® Range

| REF. AMC | SUMMARY | MAX. LOAD (KG) | CODE |
|---|---|----------------|-------|
|  <p>Grand Akustik 1+Sylomer® 60 Type A</p> | It is secured directly to the ceiling by means of two holes and to the profile by means of a "type A" screw. | 60 | 23601 |
|  <p>Grand Akustik 2+Sylomer® 60 Type A</p> | It is secured directly to the ceiling by means of one screw and to the profile by means of a "type A" screw. | 60 | 23605 |
|  <p>Grand Akustik 3+Sylomer® 60 Type A</p> | It is secured directly to the ceiling by means of one screw and to the "inverted double T" type profile thanks to the design of its metal armor. | 60 | 23607 |
|  <p>Grand Akustik 1+Sylomer® 60 Type B</p> | It is secured to the ceiling with two holes and to the profile by means of a "type B" female fixing. | 60 | 23609 |
|  <p>Grand Akustik 2+Sylomer® 60 Type B</p> | It is secured to the ceiling by a screw and to the profile by a "type B" female fixing. | 60 | 23613 |
|  <p>Grand Akustik 3+Sylomer® 60 Type B</p> | It is secured directly to the ceiling by means of a "Type B" female fixing and to the "inverted double T" type profile thanks to the design of its metal armor. | 60 | 23615 |

AKUSTIK + sylomer[®]

ACOUSTIC HANGERS

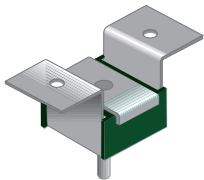
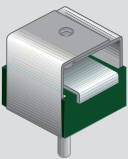
Grand Akustik+Sylomer[®] Range

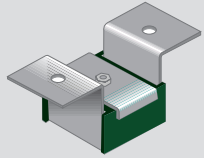
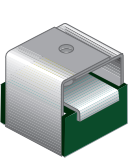
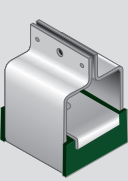
| REF. AMC | SUMMARY | MAX. LOAD (KG) | CODE |
|---|--|----------------|-------|
|  <p>Grand Akustik 1+Sylomer[®] 100 Type A</p> | It is secured directly to the ceiling with two holes and to the profile by means of a "type A" male screw. | 100 | 23594 |
|  <p>Grand Akustik 2+Sylomer[®] 100 Type A</p> | It is secured directly to the ceiling with one screw and to the profile by means of a "type A" screw. | 100 | 23596 |
|  <p>Grand Akustik 3+Sylomer[®] 100 Type A</p> | It is secured directly to the ceiling by means of one screw and to the "inverted double T" type profile thanks to the design of its metal armor. | 100 | 23598 |
|  <p>Grand Akustik 1+Sylomer[®] 100 Type B</p> | It is secured directly to the ceiling by means of two screws and to the profile by means of a "type B" female fixing. | 100 | 23595 |
|  <p>Grand Akustik 2+Sylomer[®] 100 Type B</p> | It is secured directly to the ceiling by means of one screw and to the profile by means of a "type B" female fixing. | 100 | 23597 |
|  <p>Grand Akustik 3+Sylomer[®] 100 Type B</p> | It is secured directly to the ceiling by means of one "type B" female screw and to the "inverted double T" type profile thanks to the design of its metal armor. | 100 | 23599 |

ACOUSTIC HANGERS

Grand Akustik+Sylomer® Range

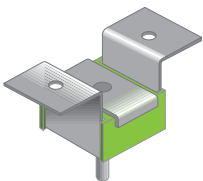
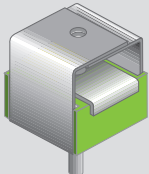
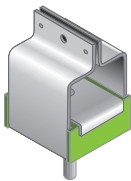
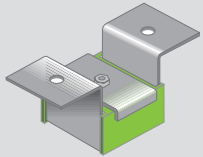
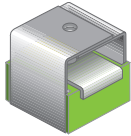
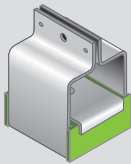
| REF. AMC | SUMMARY | MAX. LOAD (KG) | CODE |
|--|--|----------------|-------|
|  <p>Grand Akustik 1+Sylomer® 150 Type A</p> | It is secured directly to the ceiling with two holes and to the profile by means of a "type A" male screw. | 150 | 23617 |
|  <p>Grand Akustik 2+Sylomer® 150 Type A</p> | It is secured directly to the ceiling with one screw and to the profile by means of a "type A" screw. | 150 | 23621 |
|  <p>Grand Akustik 3+Sylomer® 150 Type A</p> | It is secured directly to the ceiling by means of one screw and to the "inverted double T" type profile thanks to the design of its metal armor. | 150 | 23623 |
|  <p>Grand Akustik 1+Sylomer® 150 Type B</p> | It is secured directly to the ceiling by means of two screws and to the profile by means of a "type B" female fixing. | 150 | 23625 |
|  <p>Grand Akustik 2+Sylomer® 150 Type B</p> | It is secured directly to the ceiling by means of one screw and to the profile by means of a "type B" female fixing. | 150 | 23629 |
|  <p>Grand Akustik 3+Sylomer® 150 Type B</p> | It is secured directly to the ceiling by means of one "type B" female screw and to the "inverted double T" type profile thanks to the design of its metal armor. | 150 | 23631 |

AKUSTIK + AMC Mecanocaucho & AKUSTIK+sylomer[®] by getzner

AKUSTIK + sylomer[®] by getzner

INSTALLATION INSTRUCTIONS



INSTALLATION INSTRUCTIONS
AVAILABLE ON THE QR CODE:

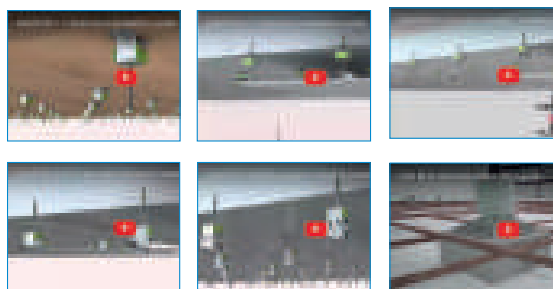

Installation steps for Akustik Super (Free technical support available upon request.)

1.- Fix threaded wall plugs to the ceiling.



2.- Screw studbolts into the threaded wall plugs.



3.- Attach the acoustic hangers to the end of the studbolt.



4.- Level the hangers using a laser alignment tool.

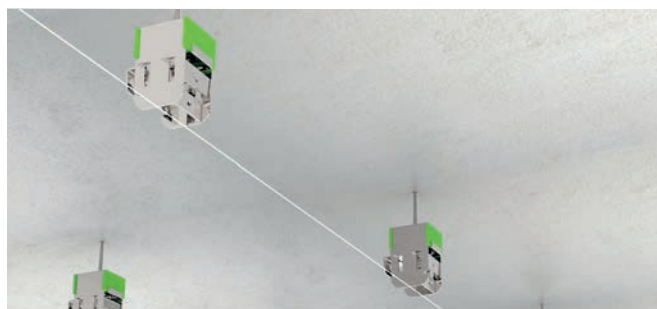

5.- Fix the profiles to the acoustic hangers.



6.- Profiles fixed in position.



7.- Lower the safety flanges into position.



8.- Install supplementary fixings (optional) to provide additional safety feature.

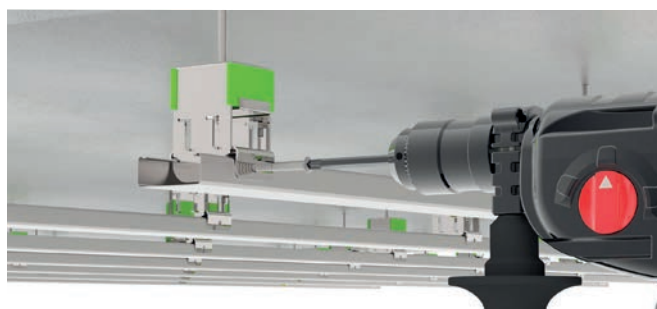

ACOUSTIC HANGERS

Installation steps (Free technical support available upon request.)

9.- Acoustic hangers and profiles fixed.



10.- Place transverse profiles in position.



11.- Fix transverse profiles.



12.- Position plasterboards in place.

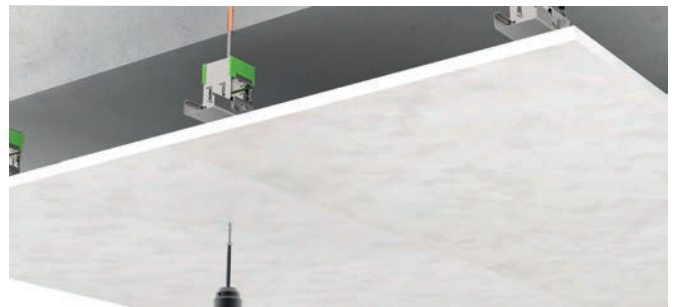

13.- Plasterboards fixed.



14.- Plasterboards fixed.

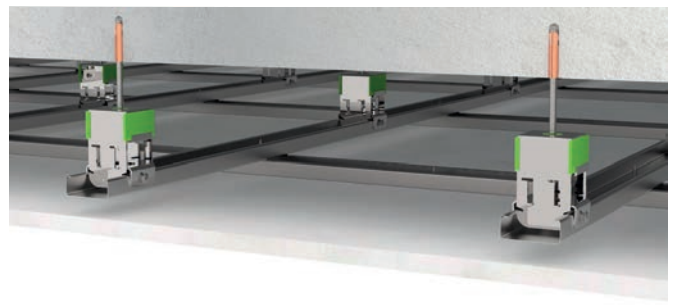

MIN/MAX Distances (Type A)

AKUSTIK SUPER T-47 TYPE A
MIN. BOLT LENGTH INSIDE WALL PLUG:
9 mm
MIN. DIST. CONCRETE SLAB TO PROFILE:
77 mm
MAX. DIST. CONCRETE SLAB TO PROFILE:
97 mm

AKUSTIK SUPER T-60 TYPE A
MIN. BOLT LENGTH INSIDE WALL PLUG:
9 mm
MIN. DIST. CONCRETE SLAB TO PROFILE:
77 mm
MAX. DIST. CONCRETE SLAB TO PROFILE:
97 mm

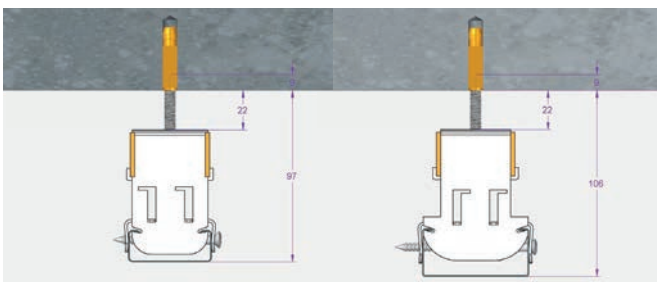

MIN/MAX Distances (Type B)

AKUSTIK SUPER T-47 TYPE B
MIN. BOLT LENGTH INSIDE WALL PLUG:
9 mm
MIN. DIST. CONCRETE SLAB TO PROFILE:
77 mm

AKUSTIK SUPER T-60 TYPE B
MIN. BOLT LENGTH INSIDE WALL PLUG:
9 mm
MIN. DIST. CONCRETE SLAB TO PROFILE:
77 mm

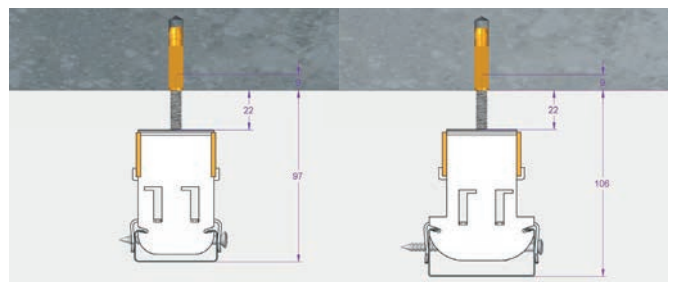

AKUSTIK + sylomer[®] by getzner

ACOUSTIC HANGERS

SRS + Sylomer[®]: Models and dimensions



PRODUCT DESCRIPTION

These antivibration mounts have been conceived for the suspension of suspended ceilings or machines that rotate at low frequency. The excellent properties of the Sylomer[®] microcellular polyurethane combined with the low stiffness of a steel spring achieve increased isolation values as opposed to other mounts using rubber or cork, or a combination of both.

These antivibration mounts are manufactured in 6 different steel spring models to adapt optimal for each application.

Their rugged metal parts withstand can tensile stresses. They are supplied with an anticorrosive treatment that can resist tensile stresses up to 1000Kg withstand the toughest environments.

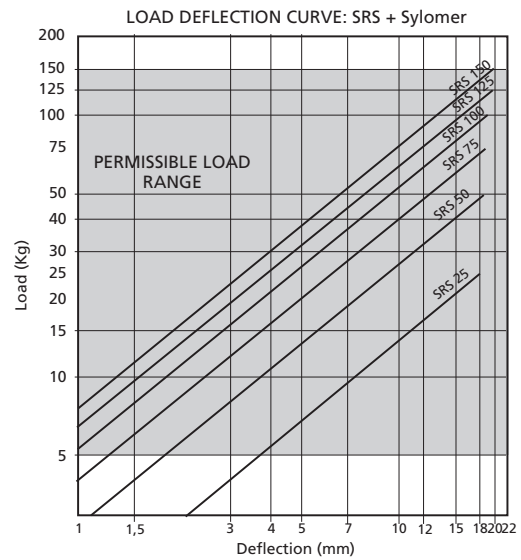
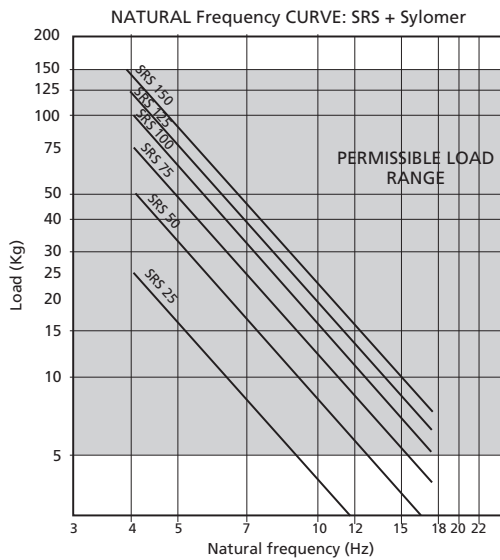
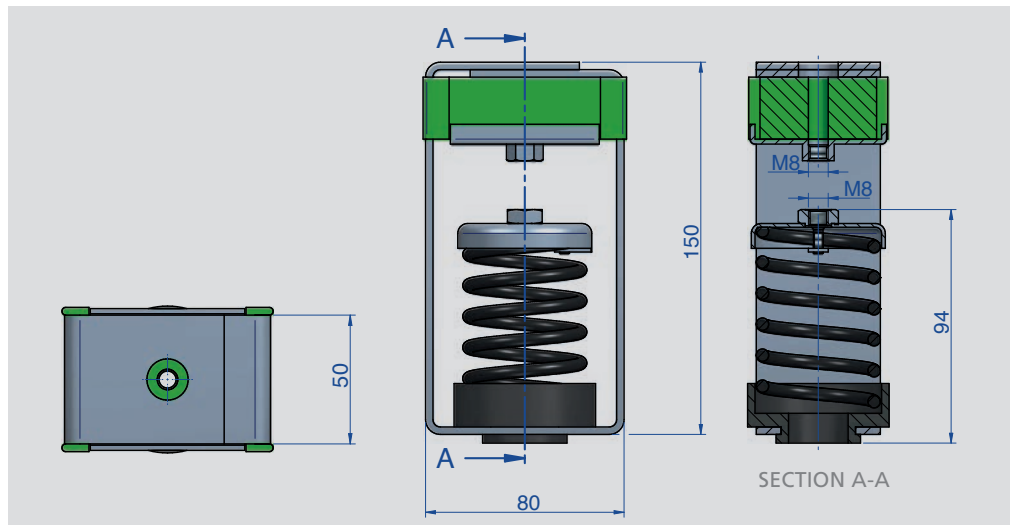
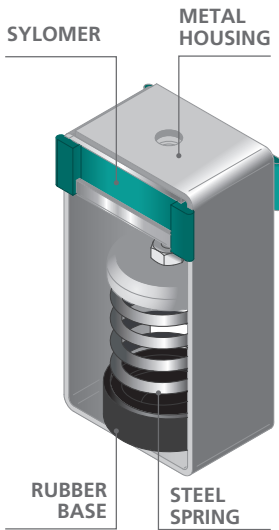

ACOUSTIC HANGERS

SRS + Sylomer®: Range

| | REF. AMC | SPRING COLOR | MAX. LOAD (KG) | CODE |
|---|--------------------|--------------|----------------|-------|
|  | SRS 25 + Sylomer® | BLACK | 25 | 23546 |
|  | SRS 50 + Sylomer® | BLUE | 50 | 23547 |
|  | SRS 75 + Sylomer® | GREY. | 75 | 23551 |
|  | SRS 100 + Sylomer® | BEIGE | 100 | 23548 |
|  | SRS 125 + Sylomer® | WHITE | 125 | 23549 |
|  | SRS 150 + Sylomer® | BLACK | 150 | 23550 |

AKUSTIK + sylomer[®] by getzner

ACOUSTIC HANGERS

ST + Sylomer[®]: Models and dimensions

PRODUCT DESCRIPTION

The AMC-MECANOCAUCHO[®] type ST+Sylomer[®] is ideal for high performance building acoustics as well as for stationary applications where the acoustic hanger must provide a high degree of structure borne noise isolation. Thanks to their low

stiffness they are capable of achieving natural frequencies ranging from 3 to 4Hz. Due to this fact they are often used on applications where a high isolation degree is required even at low disturbing frequencies (600 to 1000 rpm).

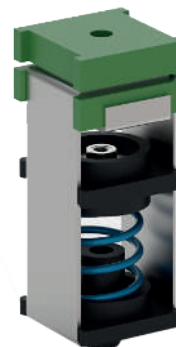

| Type | MAX PERMANENT LOAD | Weight (kg) | Code |
|--------------------|--------------------|-------------|-------|
| ST + Sylomer ST-5 | 5 | 0,198 | 23425 |
| ST + Sylomer ST-10 | 10 | 0,198 | 23398 |
| ST + Sylomer ST-20 | 20 | 0,198 | 23420 |
| ST + Sylomer ST-30 | 30 | 0,198 | 23400 |
| ST + Sylomer ST-60 | 60 | 0,198 | 23397 |

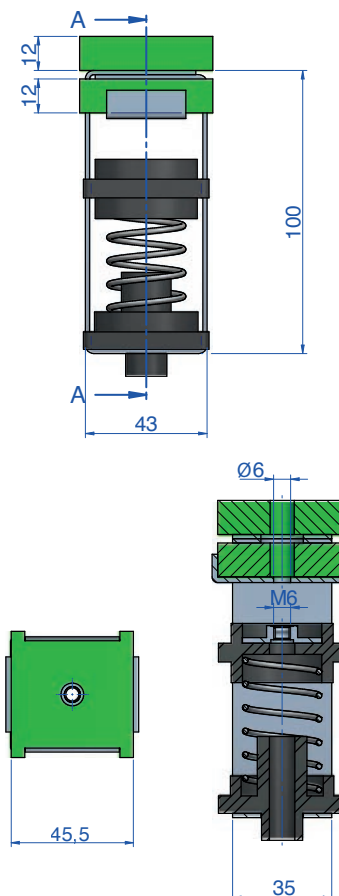
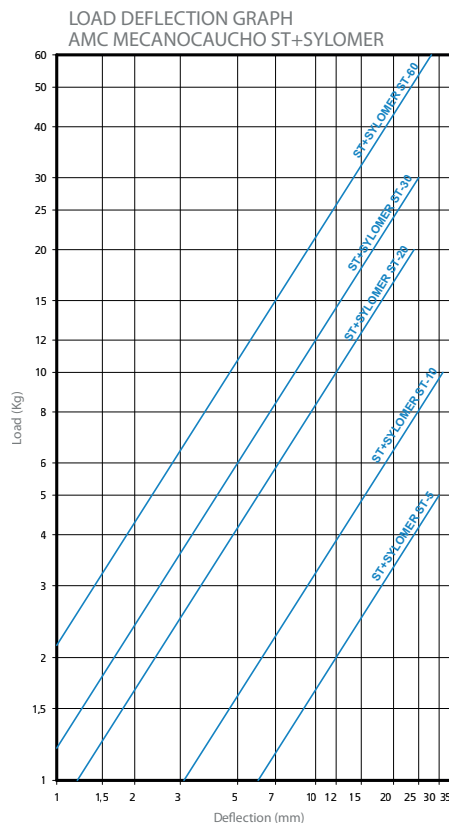
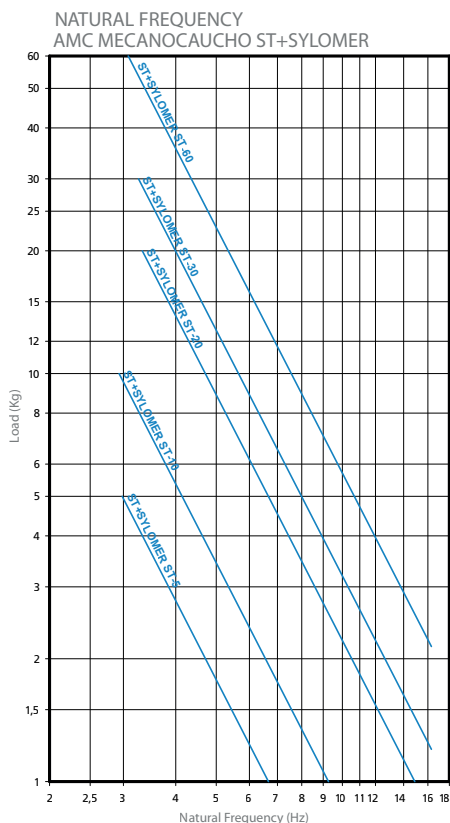

ACOUSTIC WALL TIES

EP+Sylomer®: Models and dimensions

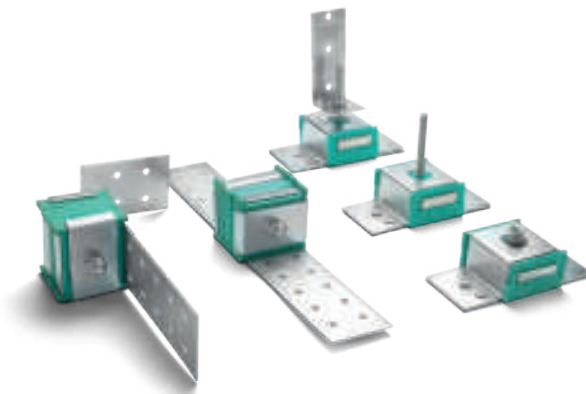

PRODUCT DESCRIPTION

Range designed for the floating suspension of soundproofed walls. Sylomer® avoids the transmission of vibrations while providing optimal acoustic results.

They have a "FAIL SAFE" rugged metal structure, which is overload-proof. Recommended for applications where fire or impact resistance is necessary.

These mounts are also suitable for the isolation of vertical pipes, or any type of lightweight ducts that need to be isolated.

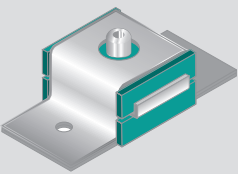

EP+Sylomer® Type B

It is secured to the wall by means of two holes. It has a female M6 metal insert.

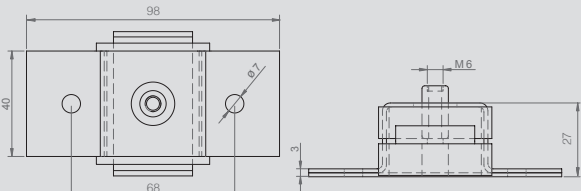

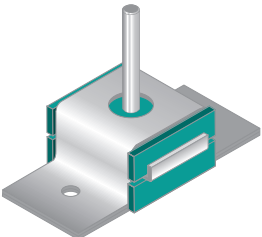

EP + Sylomer Type A

It is secured to the wall by means of two holes. It has a female M6 metal insert.

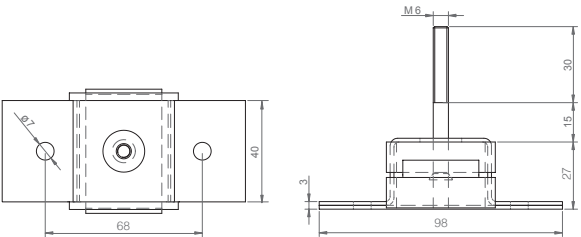

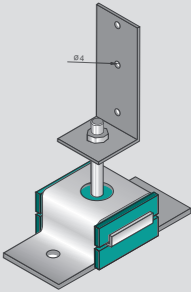

EP400 + Sylomer

It is secured to the wall by means of two holes. It has a male M6 metal insert and also an "L" welded nut for securing to the profile.

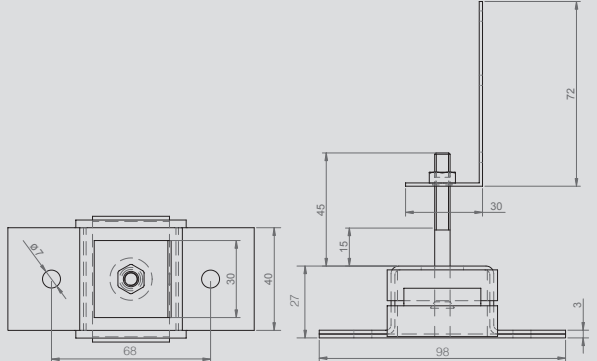

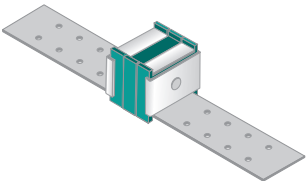

EP 600 + Sylomer

They are secured by two "predrilled" and easy-to-cut pins to facilitate their installation.

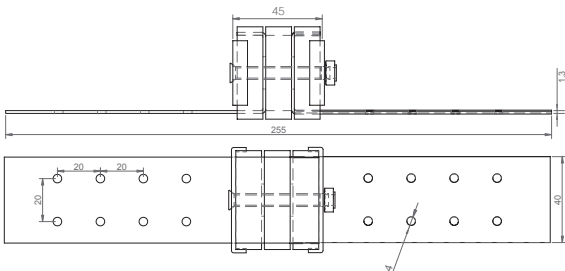

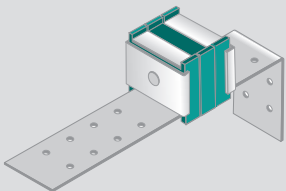

EP 650 + Sylomer

They are secured by two "predrilled" and bent pins to facilitate their installation.

This principle can be used to make a wide range of variants.

Contact us if you require a product more adapted to your building technique.

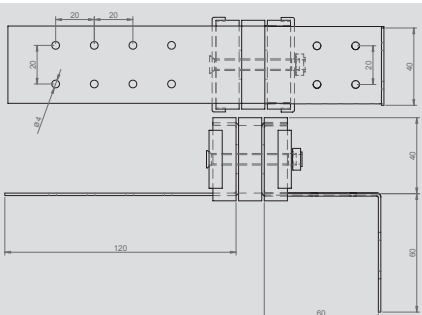

AKUSTIK + sylomer[®] by getzner

ACOUSTIC WALL TIES

EP+Sylomer[®]: Models and dimensions

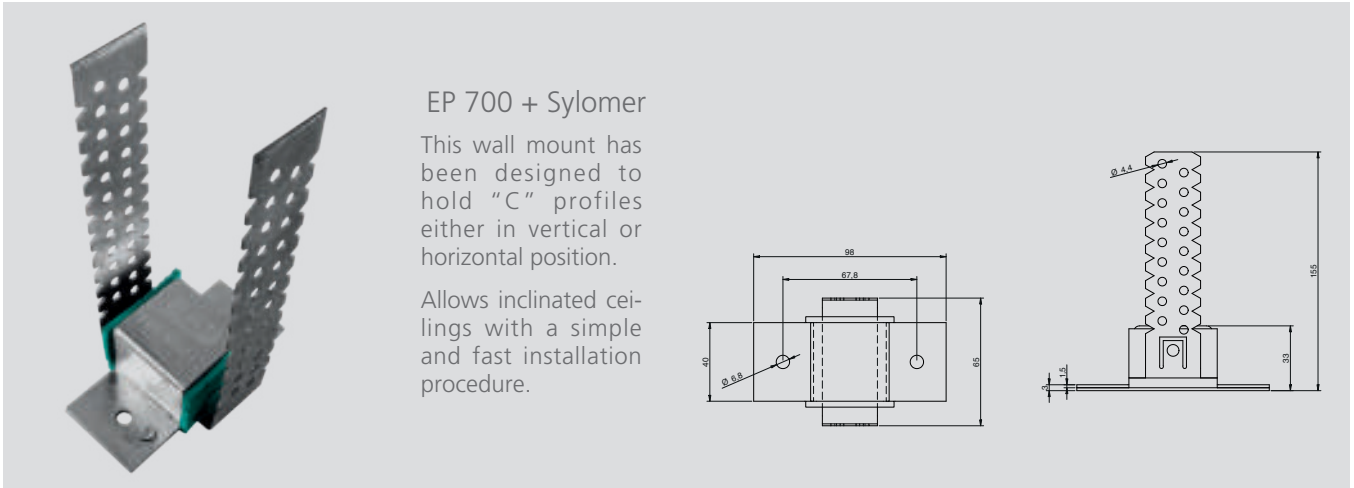

EP 700 Super + Sylomer

They are secured by two "predrilled" and bent pins to facilitate their installation.

This principle can be used to make a wide range of variants.

Contact us if you require a product more adapted to your building technique.

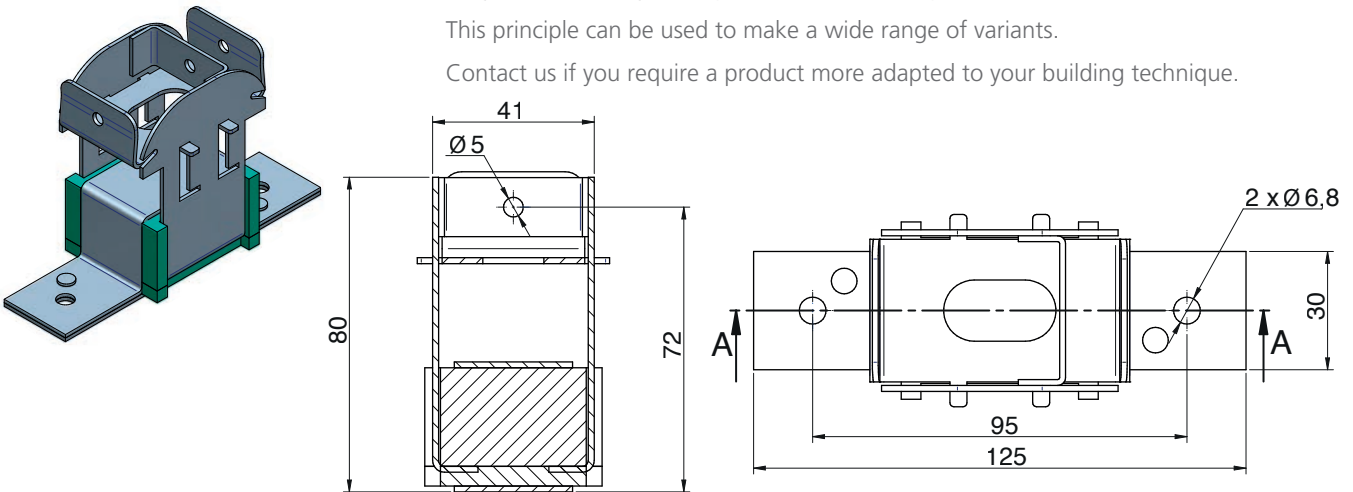

TECHNICAL CHARACTERISTICS

LOAD DEFLECTION GRAPH
EP Akustik+Sylomer[®]

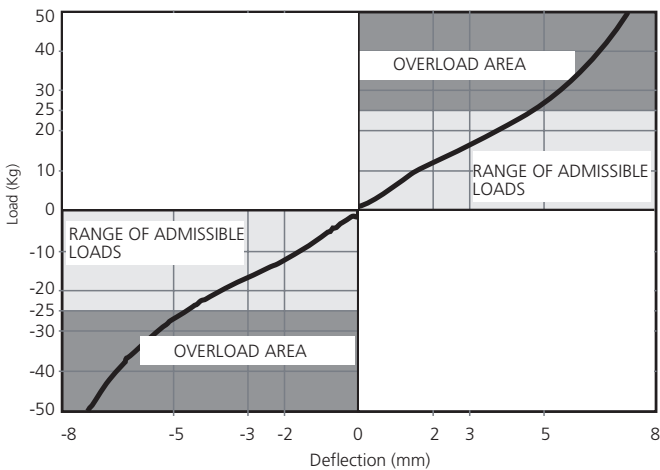

NATURAL FREQUENCY GRAPH
EP Akustik+Sylomer[®]

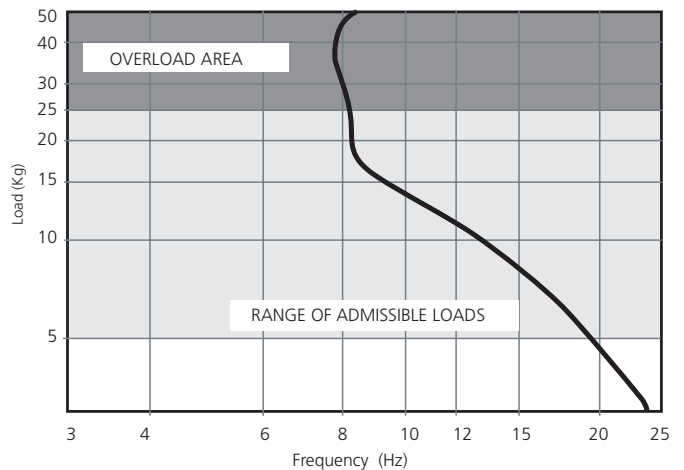

ACOUSTIC WALL TIES EP+Sylomer® Range

| | REF. AMC | MAX. LOAD (KG) | CODE |
|---|---------------------------|----------------|-------|
|  | EP + Sylomer Type B M6 | 25 | 23701 |
|  | EP + Sylomer Type B M8 | 25 | 23720 |
|  | EP + Sylomer Type A M6 | 25 | 23703 |
|  | EP 400 + Sylomer | 25 | 23705 |
|  | EP + Sylomer Type A M8 | 25 | 23702 |
|  | EP 500 + Sylomer s35 | 60 | 23715 |
|  | EP 500 + Sylomer s65 | 60 | 23716 |
|  | EP 600 + Sylomer | 25 | 23707 |
|  | EP 650 + Sylomer | 25 | 23709 |
|  | EP 700 + Sylomer 30 | 30 | 23711 |
|  | EP 700 + Sylomer 75 | 75 | 23712 |
|  | EP 700 Super + Sylomer 30 | 30 | 23745 |
|  | EP 700 Super + Sylomer 75 | 75 | 23746 |

AKUSTIK + AMC Mecanocaucho & AKUSTIK+sylomer[®]

AKUSTIK + sylomer[®] by getzner

ACOUSTIC WALL TIES

EP+ Sylomer[®]: Applications



Euskalduna Auditorium Bilbao



Music School Helsinki

TSR+Sylomer®

Models and dimensions

DESCRIPTION

The AMC-MECANOCAUCHO® TSR type anti-vibration mounts include a microcellular and resilient polyurethane compound for anti-vibration purposes called Sylomer®. This Sylomer® is oil resistant and with a temperature range of -30°C/+70°C. The TSR mounts can be fixed mechanically thanks to the internal nut incorporated to the metallic part that is treated with an antioxidant coat. This coating complies to the RoHS regulations.

The above Chloroprene based rubber that is bonded to the metal acts as an anti-skid surface for those application where a mechanical fixation is not possible to be made. This layer provides an additional anticorrosive protection. In order to match the application, 6 different densities are supplied for a wide range of loads.



| Type | Min. Load (Kg) | Max. Load (Kg) | Freq (Hz) Load Min | Freq (Hz) Max Load | CODE |
|--------------------------------|----------------|----------------|--------------------|--------------------|--------|
| TSR - 55 M8 | 10 | 25 | 23,8 | 11 | 157001 |
| TSR - 110 M8 | 25 | 45 | 17,4 | 11,1 | 157002 |
| TSR - 220 M8 | 45 | 75 | 16 | 11,1 | 157003 |
| TSR - 450 M8 | 75 | 150 | 15,5 | 10,4 | 157004 |
| TSR - 850 M8 | 150 | 250 | 14,2 | 11,1 | 157005 |
| TSR - 1200 M8 | 250 | 300 | 11 | 10 | 157006 |
| TSR - 55 M10 | 10 | 25 | 23,8 | 11 | 157008 |
| TSR - 110 M10 | 25 | 45 | 17,4 | 11,1 | 157009 |
| TSR - 220 M10 | 45 | 75 | 16 | 11,1 | 157010 |
| TSR - 450 M10 | 75 | 150 | 15,5 | 10,4 | 157011 |
| TSR - 850 M10 | 150 | 250 | 14,2 | 11,1 | 157012 |
| TSR - 1200 M10 | 250 | 300 | 11 | 10 | 157013 |
| TSR - 55 M12 | 10 | 25 | 23,8 | 11 | 157014 |
| TSR - 110 M12 | 25 | 45 | 17,4 | 11,1 | 157015 |
| TSR - 220 M12 | 45 | 75 | 16 | 11,1 | 157016 |
| TSR - 450 M12 | 75 | 150 | 15,5 | 10,4 | 157017 |
| TSR - 850 M12 | 150 | 250 | 14,2 | 11,1 | 157018 |
| TSR - 1200 M12 | 250 | 300 | 11 | 10 | 157019 |
| TSR-55 M8 + Lev Kit. M8x55 | 10 | 25 | 23,8 | 11 | 157101 |
| TSR-110 M8+ Lev Kit. M8x55 | 25 | 45 | 17,4 | 11,1 | 157102 |
| TSR-220 M8+ Lev Kit. M8x55 | 45 | 75 | 16 | 11,1 | 157103 |
| TSR-450 M8+ Lev Kit. M8x55 | 75 | 150 | 15,5 | 10,4 | 157104 |
| TSR-850 M8+ Lev Kit. M8x55 | 150 | 250 | 14,2 | 11,1 | 157105 |
| TSR-1200 M8+ Lev Kit. M8x55 | 250 | 300 | 11 | 10 | 157106 |
| TSR-55 M10+ Lev Kit. M10x90 | 10 | 25 | 23,8 | 11 | 157107 |
| TSR-110 M10+ Lev Kit. M10x90 | 25 | 45 | 17,4 | 11,1 | 157108 |
| TSR-220 M10+ Lev Kit. M10x90 | 45 | 75 | 16 | 11,1 | 157109 |
| TSR-450 M10+ Lev Kit. M10x90 | 75 | 150 | 15,5 | 10,4 | 157110 |
| TSR-850 M10+ Lev Kit. M10x90 | 150 | 250 | 14,2 | 11,1 | 157111 |
| TSR-1200 M10+ Lev Kit. M10x90 | 250 | 300 | 11 | 10 | 157112 |
| TSR-55 M12+ Lev Kit. M12x100 | 10 | 25 | 23,8 | 11 | 157113 |
| TSR-110 M12+ Lev Kit. M12x100 | 25 | 45 | 17,4 | 11,1 | 157114 |
| TSR-220 M12+ Lev Kit. M12x100 | 45 | 75 | 16 | 11,1 | 157115 |
| TSR-450 M12+ Lev Kit. M12x100 | 75 | 150 | 15,5 | 10,4 | 157116 |
| TSR-850 M12+ Lev Kit. M12x100 | 150 | 250 | 14,2 | 11,1 | 157117 |
| TSR-1200 M12+ Lev Kit. M12x100 | 250 | 300 | 11 | 10 | 157118 |

TSR without a levelling kit.

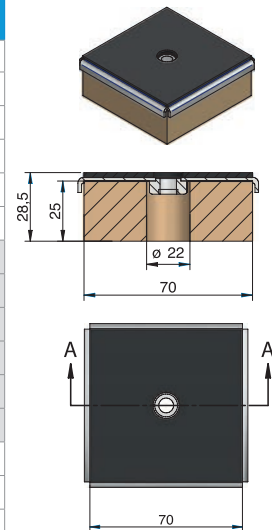

TSR with a levelling kit.

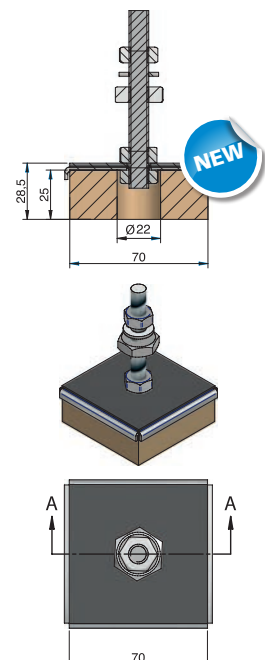

AKUSTIK + sylomer[®] by getzner

TSR+Sylomer[®] Range

| | REF. AMC | MAX. LOAD (KG) | CODE |
|---|-------------------------------|----------------|--------|
|  | TSR 55+Sylomer [®] | 25 | 157001 |
|  | TSR 110+Sylomer [®] | 45 | 157002 |
|  | TSR 220+Sylomer [®] | 75 | 157003 |
|  | TSR 450+Sylomer [®] | 150 | 157004 |
|  | TSR 850+Sylomer [®] | 250 | 157005 |
|  | TSR 1200+Sylomer [®] | 300 | 157006 |



LOAD DEFLECTION CURVES
TSR + SYLOMER[®]

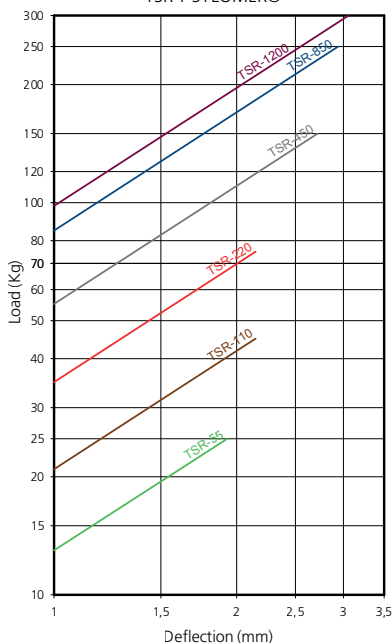

NATURAL FREQUENCY CURVES
TSR + SYLOMER[®]

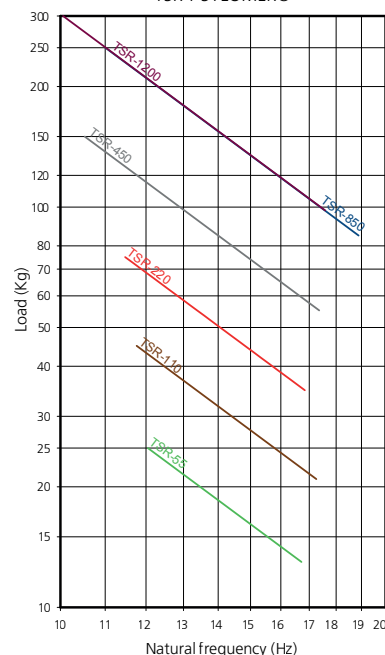

TSR+Sylomer® 100x100

| Type | MIN. LOAD (Kg) | MAX. LOAD (KG) | Freq (Hz) Load Min | Freq (Hz) Max Load | CODE |
|--|----------------|----------------|--------------------|--------------------|--------|
| TSR 100x100 SR_55 M16 + Lev Kit. M16x130 | 20 | 51 | 25,4 | 12,7 | 157071 |
| TSR 100x100 SR_110 M16 + Lev Kit. M16x130 | 51 | 106 | 18,6 | 10,8 | 157072 |
| TSR 100x100 SR_220 M16 + Lev Kit. M16x130 | 106 | 194 | 16,1 | 10,4 | 157073 |
| TSR 100x100 SR_450 M16 + Lev Kit. M16x130 | 194 | 387 | 14,9 | 10 | 157074 |
| TSR 100x100 SR_850 M16 + Lev Kit. M16x130 | 387 | 638 | 14,5 | 11,3 | 157075 |
| TSR 100x100 SR_1200 M16 + Lev Kit. M16x130 | 638 | 821 | 12 | 10,5 | 157076 |
| TSR 100x100 SR_55 M16 | 20 | 51 | 25,4 | 12,7 | 157083 |
| TSR 100x100 SR_110 M16 | 51 | 106 | 18,6 | 10,8 | 157084 |
| TSR 100x100 SR_220 M16 | 106 | 194 | 16,1 | 10,4 | 157085 |
| TSR 100x100 SR_450 M16 | 194 | 387 | 14,9 | 10 | 157086 |
| TSR 100x100 SR_850 M16 | 387 | 638 | 14,5 | 11,3 | 157087 |
| TSR 100x100 SR_1200 M16 | 638 | 821 | 12 | 10,5 | 157088 |

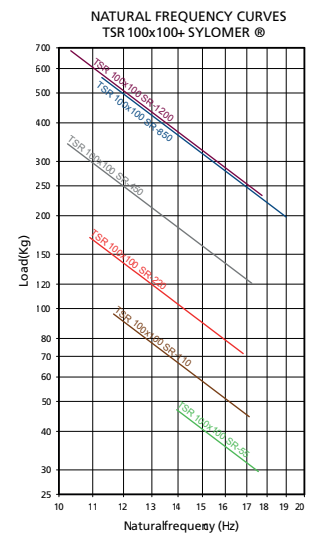
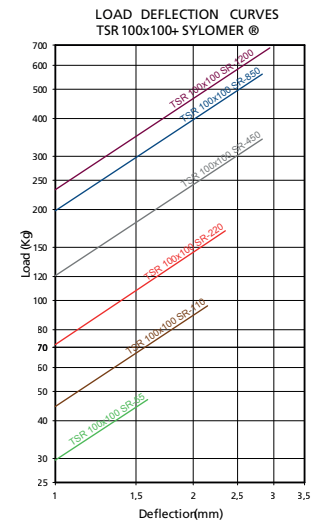
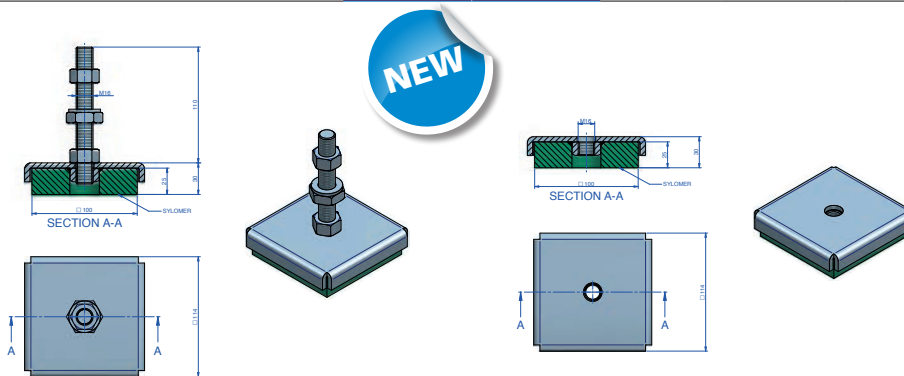

TSR+Sylomer® 150x150

| Type | MIN. LOAD (Kg) | MAX. LOAD (KG) | Freq (Hz) Load Min | Freq (Hz) Max Load | CODE |
|--|----------------|----------------|--------------------|--------------------|--------|
| TSR 150x150 SR_110 M16 + Lev Kit. M16x130 | 100 | 240 | 19,8 | 10,6 | 157120 |
| TSR 150x150 SR_220 M16 + Lev Kit. M16x130 | 240 | 450 | 16,1 | 10,3 | 157121 |
| TSR 150x150 SR_450 M16 + Lev Kit. M16x130 | 450 | 900 | 14,7 | 9,9 | 157122 |
| TSR 150x150 SR_850 M16 + Lev Kit. M16x130 | 900 | 1500 | 14,5 | 11,3 | 157123 |
| TSR 150x150 SR_1200 M16 + Lev Kit. M16x130 | 1500 | 2000 | 14,5 | 12,4 | 157124 |
| TSR 150x150 SR_110 M16 | 100 | 240 | 19,8 | 10,6 | 157125 |
| TSR 150x150 SR_220 M16 | 240 | 450 | 16,1 | 10,3 | 157126 |
| TSR 150x150 SR_450 M16 | 450 | 900 | 14,7 | 9,9 | 157127 |
| TSR 150x150 SR_850 M16 | 900 | 1500 | 14,5 | 11,3 | 157128 |
| TSR 150x150 SR_1200 M16 | 1500 | 2000 | 14,5 | 12,4 | 157129 |

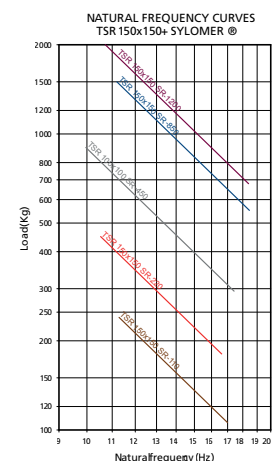
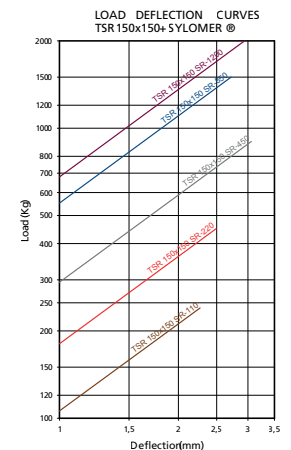
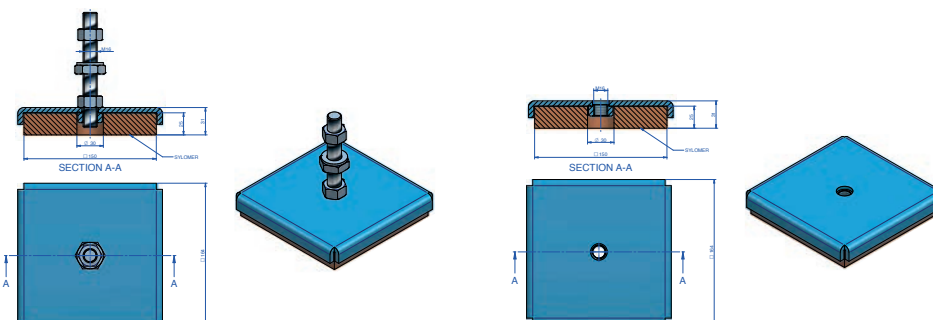

AKUSTIK + sylomer®

FLOATING FLOOR MOUNTS FZH+Sylomer®

DESCRIPTION

The goal of the system is to avoid the structure borne noise installing elastical mounts that are embedded in the concrete floating floor .The process of elevation is done once the concrete is dry.

The AMC-MECANOCAUCHO type FZH mounts incorporate a polyurethane elastomer called Sylomer®. This material offers optimal elastic and mechanical properties for the application.

The AMC-MECANOCAUCHO type FZH mounts can be manufactured in different densities of Sylomer to match the natural frequency needed on the application.

The process of leveling is simple and effective. The density of mount per m² is 1.12 and the distance between the mounts is 1.2 m.

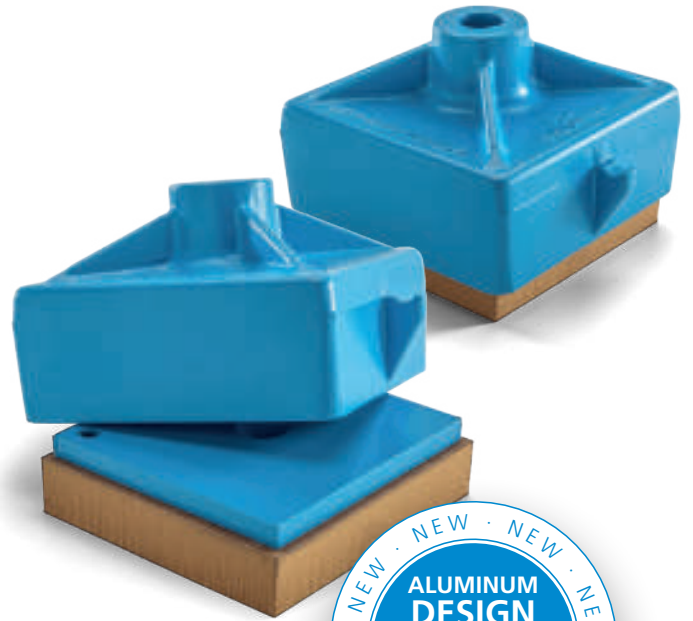

INSTALLATION

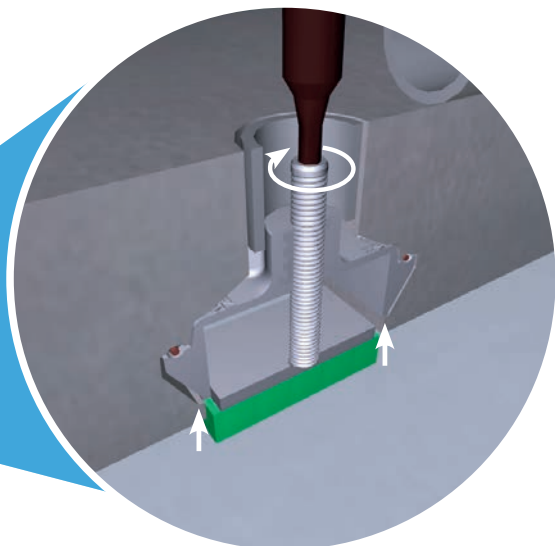
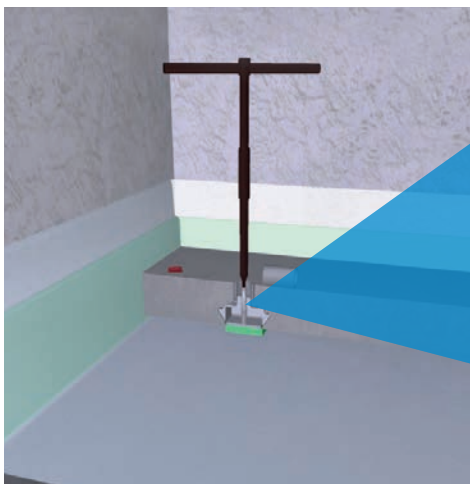
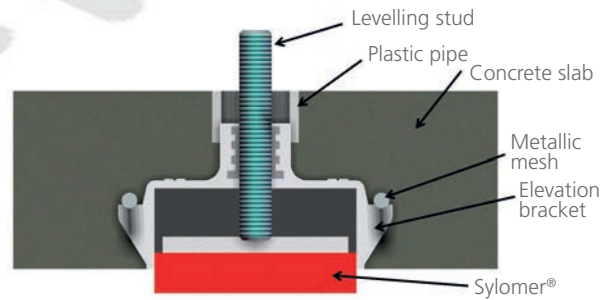
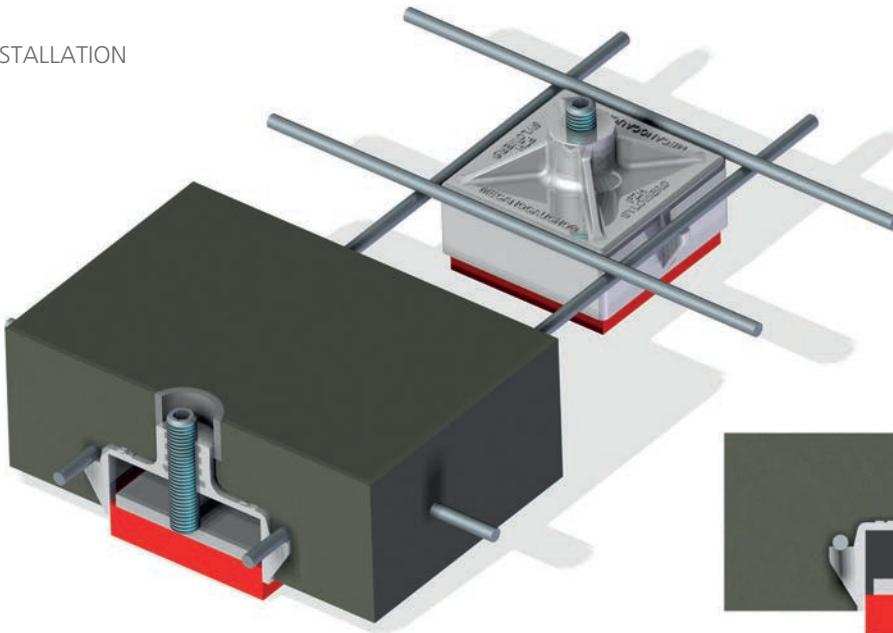

FLOATING FLOOR MOUNTS

FZH+Sylomer® Range

| Type | | MAX. LOAD (KG) | Freq (Hz) Max Load | CODE |
|---|-----------|----------------|--------------------|--------|
|  | FZH-33-25 | 140 | 11 | 176511 |
|  | FZH-33-37 | 140 | 8,6 | 176512 |
|  | FZH-39-25 | 240 | 11,1 | 176513 |
|  | FZH-39-37 | 240 | 8,5 | 176514 |
|  | FZH-45-25 | 490 | 10,4 | 176515 |
|  | FZH-45-37 | 490 | 8,1 | 176516 |
|  | FZH-51-25 | 800 | 11,8 | 176517 |
|  | FZH-51-37 | 800 | 9,1 | 176518 |
|  | FZH-57-25 | 960 | 11,7 | 176519 |
|  | FZH-57-37 | 960 | 8,4 | 176520 |

ADVANTAGES:

- **Lower height of the screed.** Optimum acoustic efficiency without high concrete thickness.
- This floor mount is specially interesting for those rooms who have limited space and can not use a conventional floor mount that increases the height of the floor.
- **Good isolation,** thanks to the antivibration properties of the Sylomer®. Low frequencies can be achieved providing an optimum isolation.
- **Quick installation,** no need to use plywood boards or joints between them.
- **Cost effective,** no need to use plywood boards nor joints.
- **Safe,** acoustic bridges are avoided when levelling the concrete floor.
- **Simple installation,** no specialist installators are needed.

CHARACTERISTICS

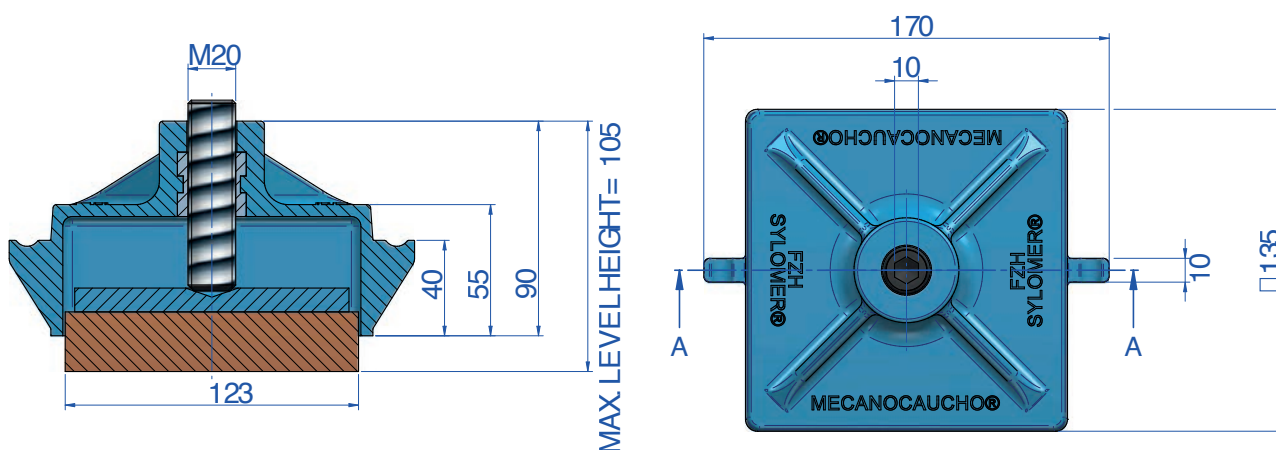



INSTALLATION STEPS

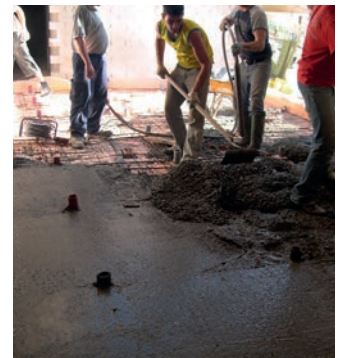
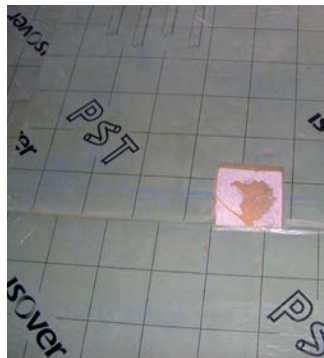

Conditioning the premise and installation of the mounts.

Installation of reinforced concrete.



Levelling.

Height adjustment.

COMPARATIVE TESTS AT THE LABEIN TECHNOLOGY CENTRE

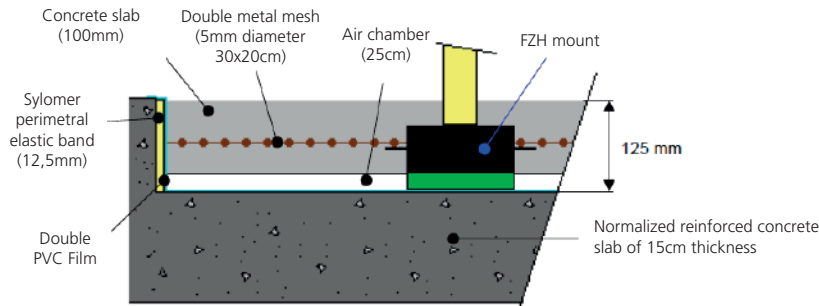

Reduction of impact noise on normalized slab according to UNE en ISO 140-8:1998

Weighted gain according to UNE-EN ISO 717-2:1997 $\Delta L_w (C_{\lambda})$: 34 (-11) dB

These results rely on the realized tests under an artificial source under Laboratory conditions (engineering method)
* $L_n \leq$ indicated value and $\Delta L \geq$ indicated value (measurement limits)

Laboratory measurements

Test specimen: Floating reinforced concrete slab of 100mm thickness, elevated at 25mm with a system of antivibration mounts as described on the above picture.

Employed supporting slab: Reinforced concrete slab of 15cm thickness, tested in 26/06/09 ($L_{n,0}$)

Volume of the receiving room: 64.7m³

Volume of the source room: 53.6m³

Surface of the test specimen: 13.86m² (3.3x4.2m)

Estimated specific mass: 250Kg/m²

Chamber temperature: 17.3 C°

Chamber Hygrometry: 77%

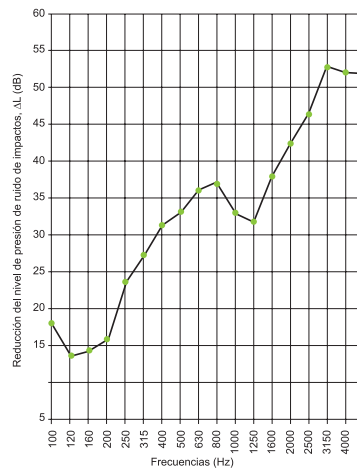

| f (Hz) | L_n (dB) | $L_{n,0}$ (dB) | ΔL (dB) |
|-----------------------|------------|----------------|-----------------|
| 100 | 47,2 | 65,1 | 17,9 |
| 125 | 46,9 | 60,5 | 13,6 |
| 160 | 53,2 | 67,5 | 14,3 |
| 200 | 49,5 | 65,3 | 15,8 |
| 250 | 41,8 | 65,4 | 23,6 |
| 315 | 37,3 | 64,7 | 27,4 |
| 400 | 34,5 | 65,9 | 31,4 |
| 500 | 34,3 | 67,5 | 33,2 |
| 630 | 31,9 | 68,0 | 36,1 |
| 800 | 32,9 | 70,1 | 37,2 |
| 1000 | 37,3 | 70,4 | 33,1 |
| 1250 | 38,9 | 70,7 | 31,8 |
| 1600 | 32,5 | 70,5 | 38,0 |
| 2000 | 27,8 | 70,3 | 42,5 |
| 2500 | 22,9 | 69,3 | 46,4 |
| 3150 | 15,3* | 68,1 | 52,8* |
| 4000 | 14,1* | 66,2 | 52,1* |
| 5000 | 11,6* | 63,9 | 52,0* |
| $L_{n,w} / L_{n,0,w}$ | 41 | 76 | |

Airborne insulation according to UNE EN ISO 140-16:2007

Laboratory measurements according to UNE ISO 140-3:1995

Test specimen: Floating reinforced concrete slab of 100mm thickness, elevated at 25mm with a system of antivibration mounts as described on the above picture.

Employed supporting slab: Reinforced concrete slab of 15cm thickness, tested in 26/06/09 (R_{WITHOUT})

Volume of the receiving room: 64.7m³

Volume of the source room: 53.6m³

Surface of the test specimen: 13.86m² (3.3x4.2m)

Estimated specific mass: 250Kg/m²

Chamber temperature: 17.3 C°

Chamber Hygrometry: 77%

Isolation gain indexes:

ΔR_A : 13 dBA

ΔR_W : 13 dB

$\Delta(R_W+C)$: 13 dBA

$\Delta(R_W+C_{tr})$: 13 dBA

Evaluation based in laboratory measurements according to engineering method.
* R_{with} and $\Delta R \geq$ indicated value (measurements limits).

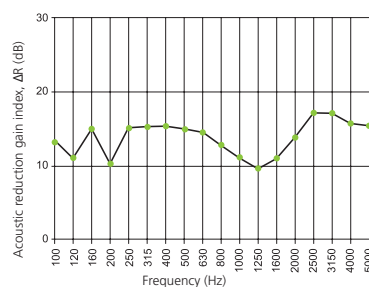

| f (Hz) | R_{with} (dB) | R_{without} (dB) | ΔR (dB) |
|-------------------|------------------------|---------------------------|-----------------|
| 100 | 48,4* | 34,8 | 13,6* |
| 125 | 53,7* | 42,6 | 11,1* |
| 160 | 54,6* | 39,6 | 15,0* |
| 200 | 58,1* | 47,6 | 10,5* |
| 250 | 63,0 | 47,7 | 15,3 |
| 315 | 67,6* | 52,3 | 15,3* |
| 400 | 70,4* | 54,9 | 15,5* |
| 500 | 71,0* | 56,0 | 15,0* |
| 630 | 72,3* | 57,7 | 14,6* |
| 800 | 72,8 | 59,8 | 13,0 |
| 1000 | 72,0 | 60,8 | 11,2 |
| 1250 | 71,9 | 62,2 | 9,7 |
| 1600 | 74,9 | 63,8 | 11,1 |
| 2000 | 80,8* | 66,8 | 14,0* |
| 2500 | 87,5* | 70,3 | 17,2* |
| 3150 | 91,2* | 74,1 | 17,1* |
| 4000 | 91,9* | 76,1 | 15,8* |
| 5000 | 92,3* | 76,9 | 15,4* |
| $R_W (C; C_{tr})$ | 72 (-2; -7) | 58 (-2; -7) | |
| R_A | 70,9 | 57,5 | |

AKUSTIK + **sylomer**[®] by getzner

ACOUSTIC MOUNT

TLG + Sylomer[®]: Applications

PRODUCT DESCRIPTION

The AMC-MECANOCAUCHO[®] TLG+Sylomer[®] anti vibration mounts have been designed to isolate structure borne noise on building applications. Their resilient material is composed of Sylomer[®] in different densities to suit different load applications.

TLG+Sylomer[®] anti vibration mounts incorporate interlocking metal component that provide a fail-safe protection. This device limits the ascending vertical movement when the mounting is submitted to shocks at traction.

The anti-corrosive properties of the Aluminum allow this part to be used in outdoor applications.

The Sylomer[®] polyurethane compound is oil resistant and provide low natural frequencies to avoid noise being transmitted through rigid structures.

APPLICATION

The TLG+Sylomer[®] is often used for the isolation of structure borne noise on frames of car park door frames, as shown on the picture below.

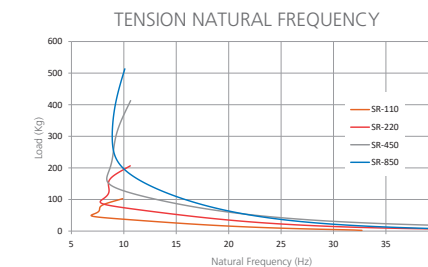
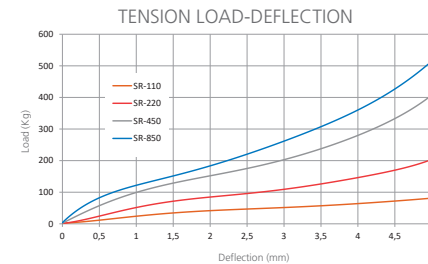
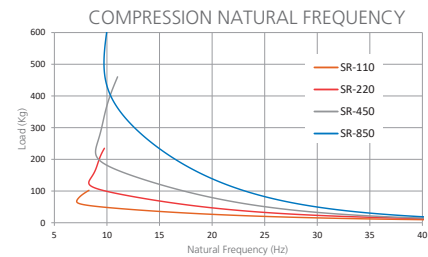
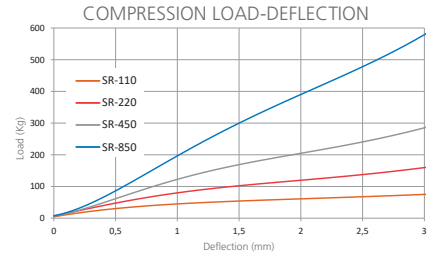
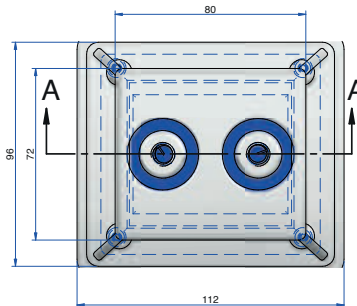
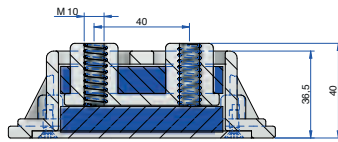
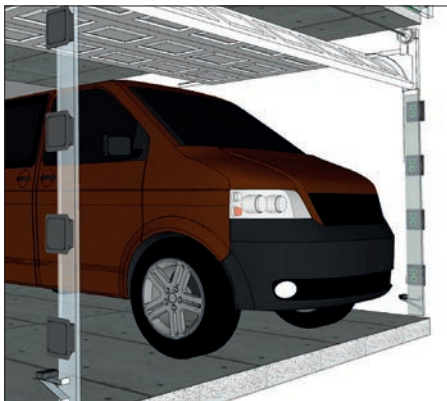

INSTALLATION:

The TLG+Sylomer[®] is often used in very different environments with space limitations. They are installed with standard DIN 6316 clamping elements. As shown on the image below.

Picture of the Mount installed with REF AMC 611533 clamps.

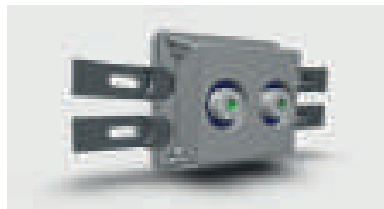

| REF. AMC | MAX. LOAD (KG) | CODE |
|-------------------|----------------|--------|
| TLG + Sylomer 110 | 40 | 176522 |
| TLG + Sylomer 220 | 75 | 176523 |
| TLG + Sylomer 450 | 120 | 176524 |
| TLG + Sylomer 850 | 190 | 176525 |

by getzner sylomer® PAD

APPLICATIONS

The pieces are made of Sylomer®, which is a very effective material for avoid the transmission of the noise and vibrations thank to its mechanical and elastic proprieties. The microcellular structure provides optimal isolation values with little deflection.

There are available three different Sylomer® densities to ideally suit different required load ranges.

The possibility to cut easily the required piece number according to the load by support makes this product very interesting for all kind of machinery thank to its adaptability.

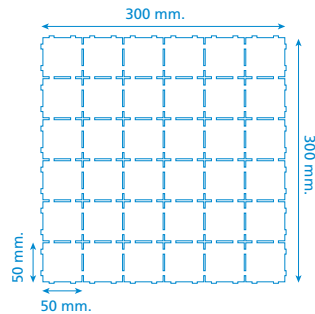

| Type | Max. Load kg/piece | THICKNESS (mm.) | Nat Freq. Hz | Weight (kg) | Code |
|------------------|--------------------|-----------------|--------------|-------------|--------|
| Sylomer® PAD 110 | 20 | 12 | 20,1 | 0,404 | 707601 |
| | | 25 | 13,7 | 0,606 | 707602 |
| Sylomer® PAD 220 | 40 | 12 | 17,4 | 0,63 | 707603 |
| | | 25 | 11,4 | 0,97 | 707604 |
| Sylomer® PAD 450 | 80 | 12 | 16,1 | 0,92 | 707605 |
| | | 25 | 10,6 | 1,345 | 707606 |

PM Sylomer® Polyurethane Supports

APPLICATIONS

AMC MECANOCAUCHO® has created a new range of Machine Foot mounts for heavy loads. In order to support these heavy weights we use a special mixture of high density polyurethane Sylomer®. Sylomer® offers a better resistance than the synthetic rubbers for oils, solvents, acids and bases.

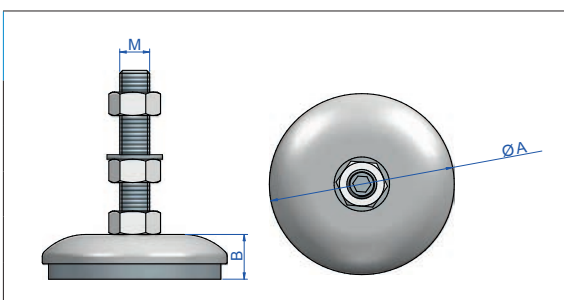

| Type | A (mm.) | B (mm.) | M | LOAD Kg. MIN | LOAD Kg. MAX | Code |
|-----------------|---------|---------|------|--------------|--------------|--------|
| PM Sylomer® 70 | 70 | 25 | M-12 | 200 | 950 | 144101 |
| PM Sylomer® 105 | 105 | 27 | M-16 | 500 | 2500 | 144102 |
| PM Sylomer® 125 | 125 | 30 | M-20 | 2000 | 4000 | 144103 |
| PM Sylomer® 165 | 165 | 35 | M-20 | 4000 | 7500 | 144104 |
| PM Sylomer® 220 | 220 | 40 | M-24 | 5000 | 11500 | 144105 |



ACOUSTIC HANGER PRO



The app that helps you find the correct acoustic hanger

1 FILL IN THE INPUT DATA

Indicate if you want to isolate a floor or a ceiling. Then introduce the weight per square meter and distance between hangers/mounts.

Location

Load

Kg/m²

Distance between points

A (cm) B (cm)

2 SELECT THE PERFORMANCE LEVEL

Introduce the natural frequency that you require. If you ignore this value you can select if your preference is high isolation or cost effectiveness. You can also select if the elastic material is rubber, Sylomer or spring.

Best price Best isolation

I know the natural frequency

Material

3 SELECT THE INSTALLATION TYPE

In case that you want to isolate a ceiling, you must indicate if the hanger has to be anchored to the slab, to the metallic beam or between rods. This will provide you a range of selected hangers and mounts that will fulfil your requirement.

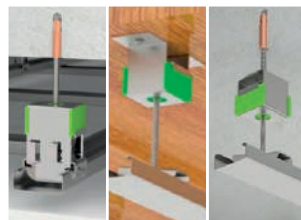

Straight to profile Straight to slab Between threaded rods

4 OBTAIN RESULTS

Select the hanger that suits best. This will lead you to a page where you will be able to check the isolation level. On this page you will be able to receive the complete vibration isolation level, data sheet, installation video or even require a quotation/ offer.



YOU WILL HAVE ACCESS TO EXTRA CONTENT:

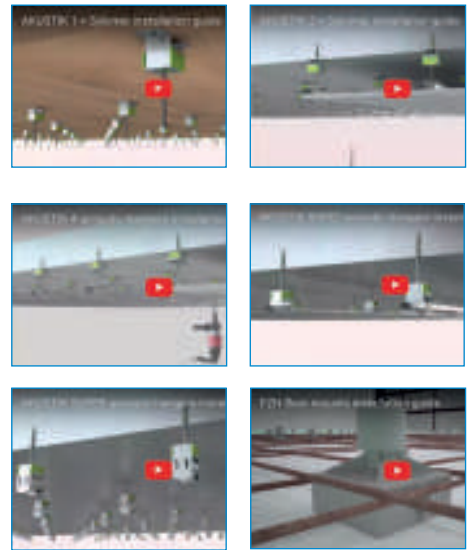

www.acoustichangerpro.com



AMC REFERENCES IN THE WORLD OF SOUND

FRANCE, ITALY, SPAIN, UNITED KINGDOM, PORTUGAL, FINLAND, GREECE...

Project: BIBLIOTHEQUE
NATIONALE DE France
Country: France

Project: CINEMA PATHÉ ECHIROLLES
Country: France

Project: CINEMA NEF CHABANT
Country: France

Project: CINEMA PATHÉ BELLE EPINE
Country: France

Project: CINÉMA PATHÉ LIEVIN
Country: France

Project: CINEMA PATHÉ LAGARDE
Country: France

Project: CINEMA PATHÉ EVRY
Country: France

Project: CINEMA PATHÉ IVRY
Country: France

Project: CINEMA UGC LUDRES
Country: France

Project: ADIDAS STORE
Country: France

Project: CLUB MED STORE
Country: France

Project: CENTRE CULTURAL
ST MEDARD
Country: France

Project: THEATRE BARBEY
Country: France

Project: CINEMA UGC TALENCE
Country: France

Project: CINEMA MK2 TOLBIAC
Country: France

Project: CINEMA UGC CRETEIL
Country: France

Project: CINEMA PATHÉ BESANÇON
Country: France

Project: CINEMA PATHÉ LINGOTTO
Country: Italy

Project: MAISON
DES MUSIQUES AMPLIFIÉES
Country: France

Project: ALOUETTES
ARDIN ALFORTVILLE
Country: France

Project: PÉPINIÈRE D'ENTREPRISES
FRICHE BELLE DE MAI
Country: France

Project: AGF ASSURANCE OFFICES
Country: France

Project: CINÉMA LES AMBASSADEURS
Country: France

Project: CASA DA MUSICA
Country: Portugal

Project: CINEMA MAIASHOPPING
Country: Portugal

Project: PALACIO EUSKALDUNA
Country: Spain

Project: BALUARTE AUDITORIO DE
NAVARRA
Country: Spain

Project: TEATRO LICEO DE BARCELONA
Country: Spain

Project: LAUREN CINEMA THX
Country: Spain

Project: AC HOTELES
Country: Spain

Project: LAUREN CINEMA THX
Country: Spain

Project: MULTICINES VALDEPEÑAS
Country: Spain

Project: CENTRO COMERCIAL
MIRAMAR
Country: Spain

Project: MAX CENTER CINES
Country: Spain

Project: CINES CORTE INGLES LISBOA
Country: Portugal

Project: CINES CARREFOUR ALICANTE
Country: Spain

Project: CENTRO COMERCIAL VIGO
Country: Spain

Project: CENTRO COMERCIAL
BOULEVARD
Country: Spain

Project: STUDIO DE TÉLÉVISION
NANTES
Country: France

Project: ZARA INDITEX
CONFERENCE HALL
Country: Spain

Project: FORUM BARCELONA
Country: Spain

Project: TERRA MITICA
Country: Spain

Project: CINEMA MAJESTIC
Country: France

Project: JDC CENTER LA SOULAIE
Country: France

Project: TEATRO ANESIS
Country: Greece

Project: RECORDING STUDIO
Country: Finland

Other Projects: BARS, DISCOTHEQUES,
CAFETERIAS, MUSEUMS, LIBRARIES,
SHOPS, PUBS.

Country: Spain, France, United
Kingdom, Italy, Portugal, Finland and
Greece.



NEW EXPOSITION TOOLS FOR THE AKUSTIK RANGE OF PRODUCTS



Tacos Sylomer® desktop exposition tool for point of sale areas



Sylomer® PAD desktop exposition tool for point of sale areas



Adapted for show rooms or point of sale areas.



TSR+Sylomer® desktop exposition tool for point of sale areas



AMC CATALOGUES



AMC-MECANOCAUCHO® ANTIVIBRATION MOUNTINGS

Rubber to metal mounts for industrial applications.



VIBRABSORBER + **sylomer**^{by getzner}® SPRING MOUNTS

Complete range of spring mounts for industrial acoustics.



Granab[®] Golvregelsystem

Acoustic and technical floor for buildings.



AKUSTIKABSORBER

Soundproofing composites for industrial applications.



sylomer^{by getzner}®

Micro-cellular polyurethane material specially conceived for vibration isolation.



ACOUSTIC HANGER PRO

Discover the app that helps you **find the correct acoustic hanger** for your application. Let your phone provide you a **full report** of isolation, **datasheets** and **videos** of installation.

SIMPLE, EASY & FREE!



Aplicaciones Mecánicas del Caucho S.A.

Industrialdea Parc 35 A. • E-20.159
ASTEASU (Gipuzkoa) Spain
Tel.: + 34 943 69 61 02 • Fax: + 34 943 69 62 19
e-mail: sales@amcsa.es
www.akustik.com
www.mecanocaucho.com

